

HardiePanel® Vertical Siding Product Description

HardiePanel® vertical siding is factory-primed fiber-cement vertical siding available in a variety of sizes and textures. Examples of these are shown below. Textures include smooth, stucco, Cedarmill® and Sierra 8. HardiePanel vertical siding is 7.5mm ($\frac{5}{16}$ in) thick and is available in 4 ft x 8 ft, 4 ft x 9ft and 4 ft x 10 ft sizes. Please see your local James Hardie dealer for texture and size availability.

HardiePanel vertical siding is available as a prefinished James Hardie® product with ColorPlus® Technology. The ColorPlus coating is a factory applied, oven baked finish available on a variety of James Hardie siding and trim products. See your local dealer for availability of products, color and accessories.



Stucco



Cedarmill®



Sierra 8



Smooth



Installation of HardiePanel® Vertical Siding

Note: James Hardie requires a minimum 3/8 in capillary break (Rainscreens, Furring, Etc.), when installing HardiePanel on a Multi-Family/Commercial project.

GETTING STARTED

First locate the lowest point of the sheathing or sill plate, and begin installation on that wall.

- 1) Measure up from the sill plate the height of the panels at either end of the wall and snap a straight, level chalk line between the marks as a reference line. That line is for guidance in positioning the top edge of the panels. Check the reference line with a 1219mm (4 ft) level.
- 2) Starting on one end and working across the wall, measure and trim the first panel making sure that the edge falls in the middle of a stud.
- 3) Using the chalk line as a guide along the panel's top edge, carefully position the panel and secure it with suitable fasteners and fastener spacing for the particular application as noted in the CCMC Report.
- 4) As installation continues, check the vertical edge of each panel with a 1219mm (4 ft) level.

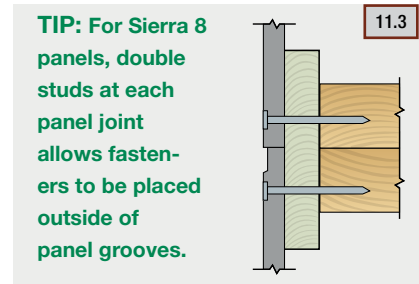
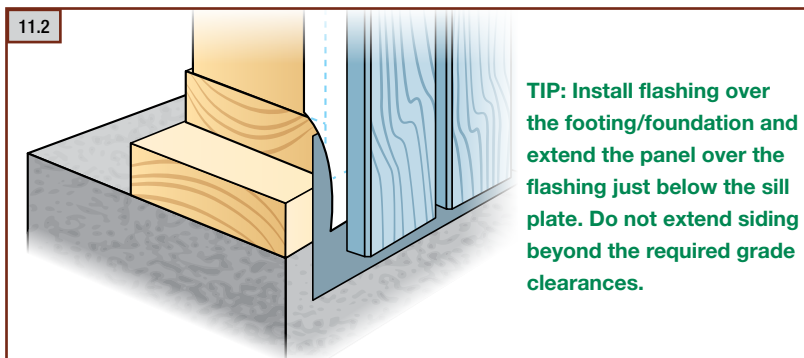
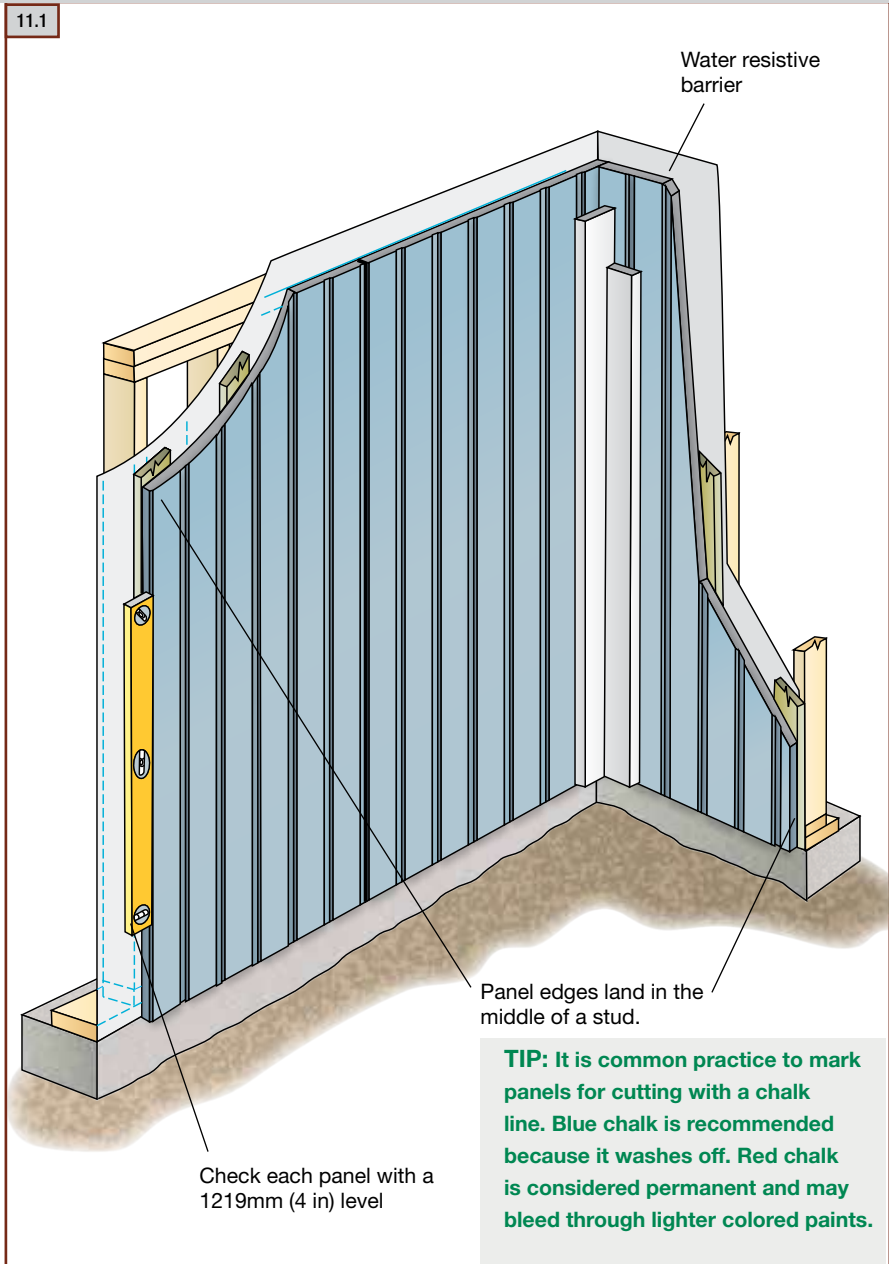

General Product Information

Working Safely

Tools for Cutting and Fastening

General Installation Requirements

General Fastener Requirements

Finishing and Maintenance

HardieTrim® Boards/Battens

HardieSoftie® Panels

HardiePlank® Lap Siding

HardieShingle® Siding

HardiePanel® Vertical Siding

Appendix/Glossary

CCMC Report

Installation of HardiePanel® Vertical Siding (continued)

VERTICAL JOINT TREATMENT

Treat vertical joints in HardiePanel® vertical siding by using one of the following four methods:

- 1) Install the panels in moderate contact.
- 2) Leave an appropriate gap between panels (3mm (1/8 in) is the most common), and caulk using a high-quality paintable caulk, that meets part 9.27.4 of the NBC requirements. (Not recommended for ColorPlus)

Panels may be installed first with caulk applied in the joints after installation; or as an option, after the first panel is installed, apply a bead of caulk along the panel edge. When the next panel is installed against the first, the edge embeds in the applied caulk creating a thorough seal between the edges of the panels.

WARNING

The caulk joint method is not recommended for the ColorPlus® products

DO NOT caulk nail head when installing ColorPlus products

- 3) Vertical joints may be covered with wood or fiber-cement batten strips. If James Hardie® siding or trim products are ripped and used as batten strips, paint or prime the cut edges. Batten strips should span the vertical joint by at least 19mm (3/4 in) on each side.
- 4) Metal or PVC “H” moldings can be used to join two sections of HardiePanel siding.

TIP: Stainless steel fasteners are recommended when installing James Hardie products.

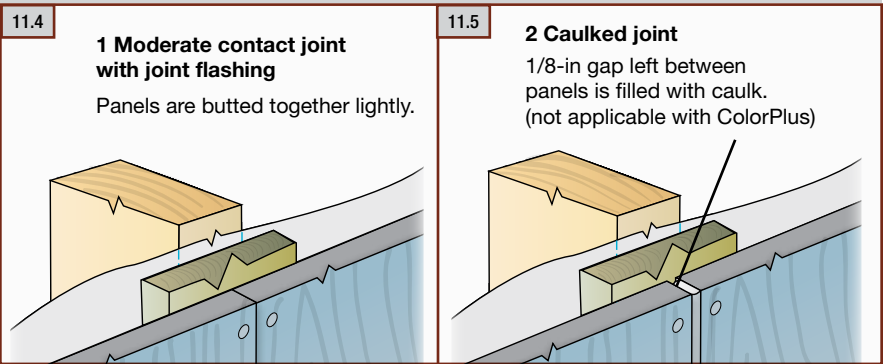

Note: The following outlines the recommended applications for ColorPlus and Primed panels. Not all designs will be suitable for every application:

- Exposed fasteners or battens is the recommended application for ColorPlus products
- Do not use touch-up over fastener heads for smooth ColorPlus products - primed panel recommended
- For ColorPlus panel applications that require fasteners in the field, it is acceptable to use touch-up over fasteners for Cedarmill and Stucco panel only, but correct touch-up application is important. Some colors may show touch-up when applied over fasteners. Trim is recommended to cover joints when appropriate.

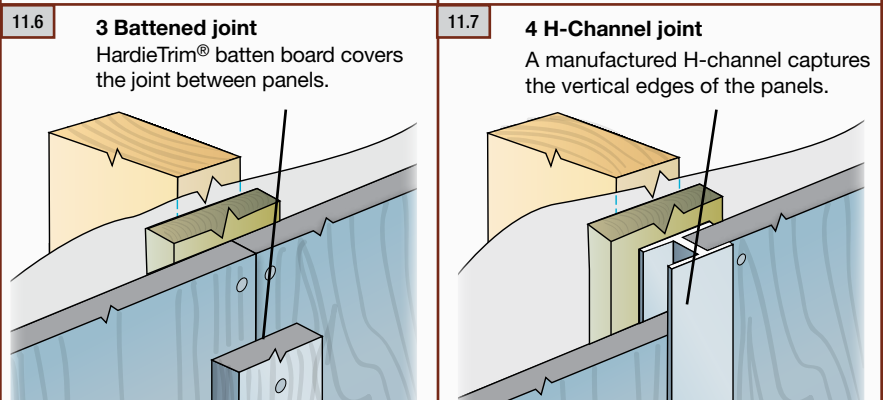

HARDIEPANEL SIDING FASTENER SPECIFICATIONS

The Fastener Specifications table shows fastener options for a variety of different nailing substrates. Please refer to the applicable Wind load tables to determine which fastener meets your wind load

| Fastening Substrate | Approved Fastener | Fastening Types |
|---------------------|---------------------------------|--|
| wood studs | 406mm (16 in) o.c. | 1 4d 3mm x 6.8mm x 38mm (0.118 in x 0.267 in x 1.5 in) |
| | | 2 6d 3mm x 6.8mm x 50.8mm (0.118 in x 0.267 in x 2 in) |
| steel studs | 16 in o.c or 406mm (16 in) o.c. | 5 ring shank siding nail 2.3mm x 5.6mm x 38.1mm (0.091 in x 0.221 in x 1.5 in) |
| | | 7 screw Ribbed Bugle-Head No. 8 8.2mm x 41.3mm (0.323 in x 1.625 in) |
| | | 13 ET&F 2.5mm x 6.4mm x 38.1mm [AGS-100] (0.100 in x 0.25 in x 1.5 in) |

HORIZONTAL JOINT TREATMENT

In some applications such as multi-story structures or at gable ends, it may be necessary to stack HardiePanel® siding. The horizontal joints created between panels must be flashed properly to minimize water penetration. Treat horizontal panel joints by using one of the following methods:

- 1) After installing the lower course of panel siding, install vinyl or coated aluminum “Z” flashing at the top edge of the panel. Make sure that the flashing is sloped away from the wall and does not rest flat on the top edge of the panel. Install the second level or gable panels leaving a 6mm (¼ in) minimum gap between the bottom of the panel and the Z flashing. This gap should never be caulked.
- 2) As an alternative, if a horizontal band board is used at the horizontal joint, flashing must extend over the panel edge and trim attachment. Flashing for both treatments must slip behind the water-resistive barrier.

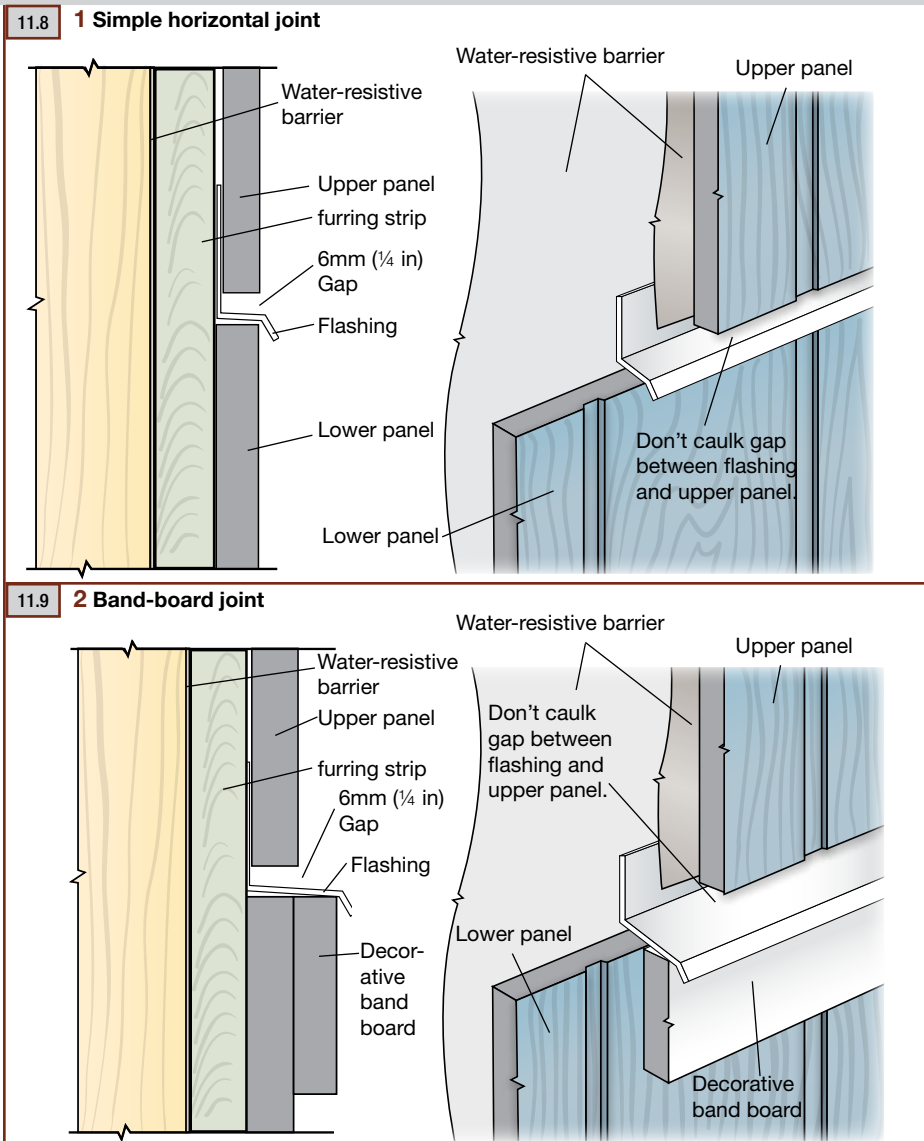

TIP: For best looking installation of HardiePanel Select Sierra 8 siding, carefully align vertical panel grooves at 1st to 2nd story or gable junctures.



WARNING

Do not bridge floors with panel siding. A horizontal joint shall always be created between floors.

TIP: For the most symmetrical looking wall, plan the installation so that a full panel is centered on the wall or gable with equal-size panels cut for each end. As an alternative, plan the installation so that a full panel is located on either side of the wall center, again leaving equal-size panels on each end. These strategies might entail a centered framing layout. Choose the strategy that looks the best and uses material most efficiently.

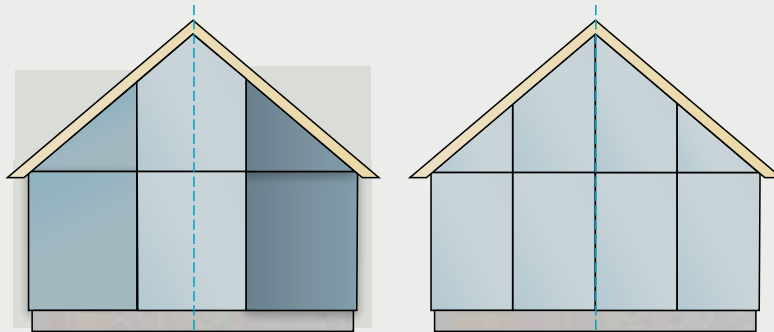

Installation of HardiePanel® Vertical Siding (continued)

General Product Information

Working Safely

Tools for Cutting and Fastening

General Installation Requirements

General Fastener Requirements

Finishing and Maintenance

HardieTrim® Boards/Battens

HardieSoffit® Panels

HardiePlank® Lap Siding

HardieShingle® Siding

HardiePanel® Vertical Siding

Appendix/Glossary

CCMC Report

WINDOWS, DOORS, AND OTHER WALL PENETRATIONS

In panel installations, trim is typically overlaid on top of the panel. Special attention needs to be paid to trim flashing at the tops of openings. Below is one method for properly flashing trim in a panel application:

- 1) After installing the window, cut and install a 6mm (¼ in) thick shim above the window. The shim should be the same width as the trim, and it should be as long as the width of the window.
- 2) Over the shim, install flashing wide enough to cover thickness of the trim and long enough to cover the trim head piece.
- 3) Install the panel to the window and around the shim taking care not to damage the flashing and leaving a 6mm (¼ in) gap between the panel and the horizontal part of the flashing.
- 4) Install the trim around the window, slipping the head piece under the installed flashing.

11.10

1 Install 6mm (¼ in) thick shim over the window.

2 Install flashing over the shim and under the water-resistant barrier.

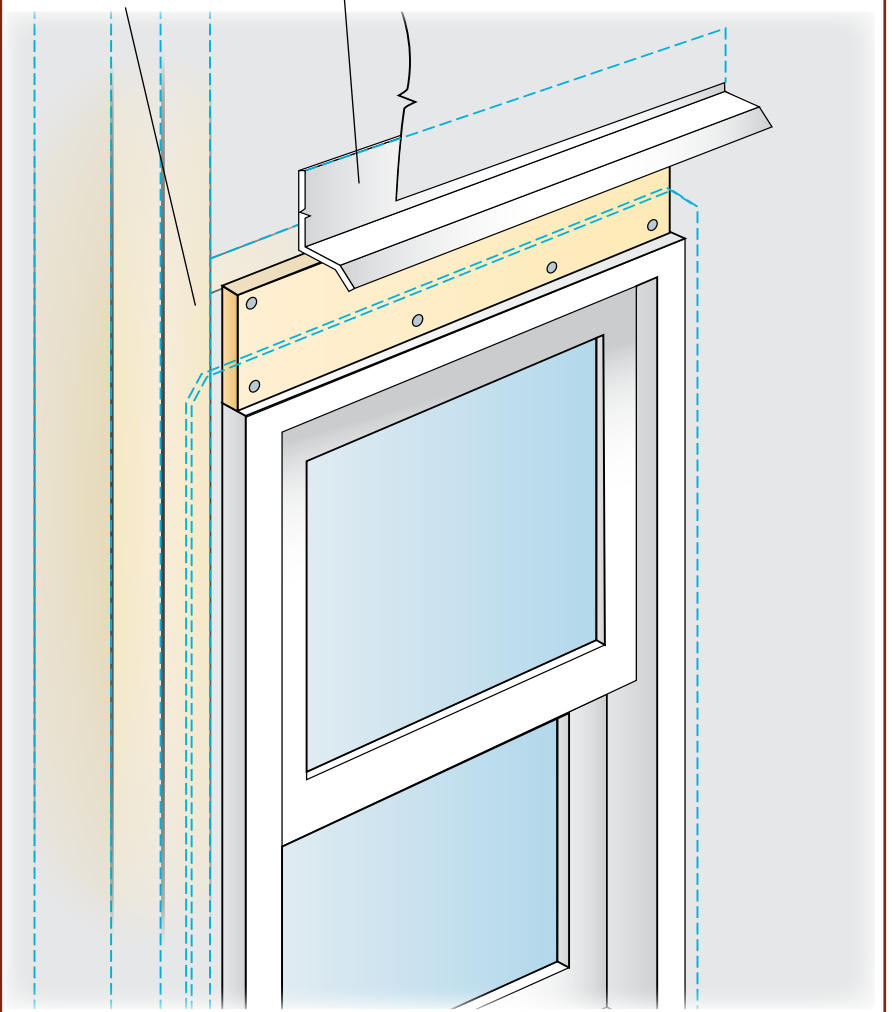

11.11

3 Cut and fit panel around the shim and flashing. Leave 6mm (¼ in) gap between the flashing and the upper panel.

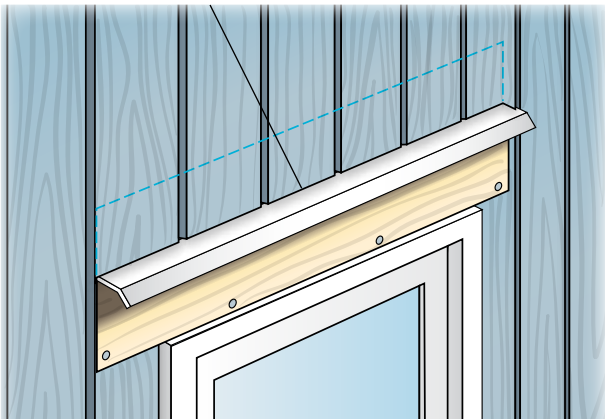

11.12

4 Install window trim under the flashing.

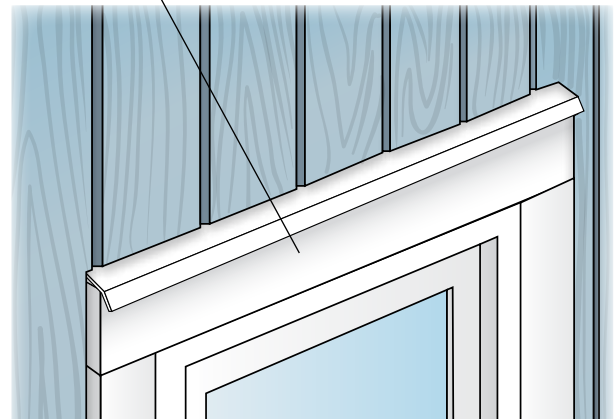

RAIN SCREENS

The Use of Rain Screen Systems:

James Hardie will support the use of its exterior siding products with rainscreen systems, but does not take sole responsibility for the entire wall assembly or system. James Hardie expects the designer or builder using our components as part of the rainscreen system to:

- Adhere to all the installation requirements listed in the relevant product installation instructions.
- Provide adequate details for water management.
- Make the decision about the use of rainscreen.
- James Hardie products does not recommend “drainage mats” or drainage boards” to provide the necessary capillary break behind our siding. These products can compress during the installation process, impairing the drainage channels and further causing a “wavy” appearance in the plank or panel products.
- Understand the interaction between system components and how each of the components in the system interacts.
- Design of the building envelope accounting for both interior and exterior moisture control.

Installation Over Furring:

When reviewing the following details for attaching to wood furring or framing, an important consideration is that the fastener chosen must be fully encompassed by a wood substrate - the furring may count as all or part of the necessary penetration if it has been proven that the furring and/or wood substrate has the same or better holding power as a timber stud.

Design responsibility

In all cases it is the sole responsibility of the architect, envelope engineer or specifier to identify moisture related risks associated with any particular building design and to make any appropriate adjustments or modifications to the installation guidelines given by manufacturers. Wall construction and design must effectively manage moisture, considering both the interior and exterior environment of the building.

Attaching panel siding to wood furring:

When attaching panel siding products over wood furring, the typical fastener used is the 6d common 50mm (2 in) long nail. This fastener is going to be the shortest fastener approved for fastening panel siding products into wood, therefore the furring must be a minimum of 43mm (1 11/16 in) thick to achieve the same values as CCMC, given stud spacing, building height, and exposure category.

It is deemed an acceptable practice to not fasten along the top and bottom plates for the 7.5mm (5/16 in) HardiePanel® configurations listed in the CCMC using the following fastener type:

- 2.3mm (0.091 in) shank X 5.7mm (0.225 in) HD X 38mm (1.5 in) long - ring shank nail
- 6d common 50mm (2 in) long - nail
- Min. No. 8 X 0.311 HD X 1 in - ribbed bugle head screw
- 2.5mm (0.10 in) X 6.4mm (0.25 in) HD X 38.1mm (1.5 in) long - ET&F pin or equivalent

Conditions of use:

- This practice is acceptable for transverse load only.
- This practice is not acceptable for racking shear values or in-plane forces other than perpendicular/normal wind forces.
- All vertical joints shall occur over framing.
- All other James Hardie Installation Requirements shall be followed.

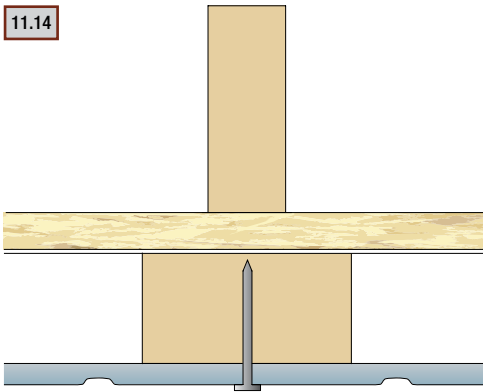
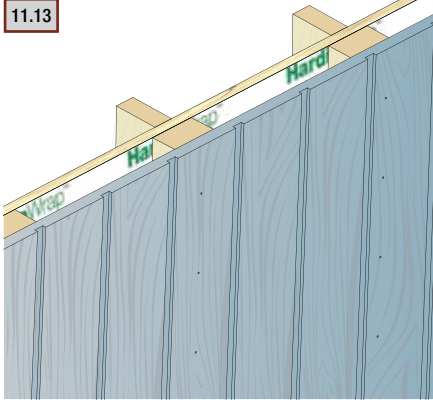

RAIN SCREENS

Attaching panel siding to steel furring:

When attaching panel siding products to metal furring, the steel furring must be a minimum 20 gauge steel. A fastener should be chosen out of the CCMC, which is approved for attaching to steel framing. Two general rules that should be considered when choosing a fastener is that a nail (pin) must penetrate steel furring 6mm (¼ in), and screws must penetrate steel furring 3 full threads. Therefore, if the rules for steel fastening are followed – given stud spacing, building height, and exposure category – the values are the same as CCMC states for the chosen fastener.

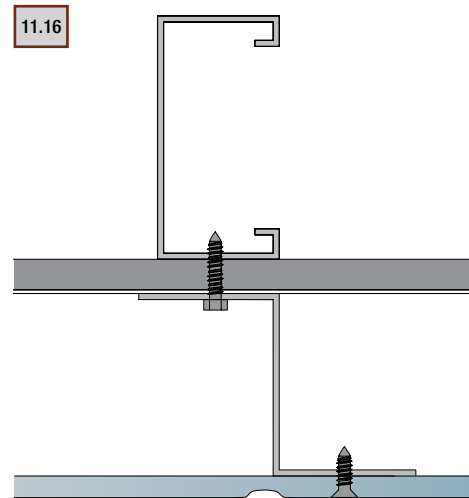
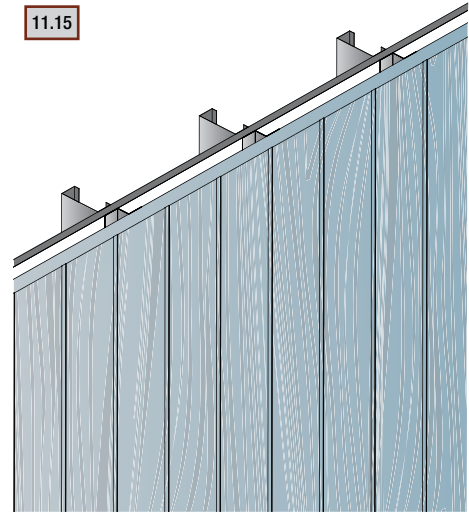



HardiePanel® Vertical Siding

SINGLE FAMILY INSTALLATION REQUIREMENTS

EFFECTIVE JANUARY 2020

IMPORTANT: FAILURE TO FOLLOW JAMES HARDIE WRITTEN INSTALLATION INSTRUCTIONS AND COMPLY WITH APPLICABLE BUILDING CODES MAY VIOLATE LOCAL LAWS, AFFECT BUILDING ENVELOPE PERFORMANCE AND MAY AFFECT WARRANTY COVERAGE. FAILURE TO COMPLY WITH ALL HEALTH AND SAFETY REGULATIONS WHEN CUTTING AND INSTALLING THIS PRODUCT MAY RESULT IN PERSONAL INJURY. BEFORE INSTALLATION, CONFIRM YOU ARE USING THE CORRECT HARDIEZONE® PRODUCT INSTRUCTIONS BY VISITING HARDIEZONE.COM OR CALL 1-866-942-7343 (866-9-HARDIE)

CUTTING INSTRUCTIONS

STORAGE & HANDLING:

Store flat and keep dry and covered prior to installation. Installing siding wet or saturated may result in shrinkage at butt joints. Carry planks on edge. Protect edges and corners from breakage. James Hardie is not responsible for damage caused by improper storage and handling of the product.

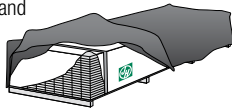

OUTDOORS

- Position cutting station so that airflow blows dust away from the user and others near the cutting area.
- Cut using one of the following methods:
 - Best:** Circular saw equipped with a HardieBlade® saw blade and attached vacuum dust collection system. Shears (manual, pneumatic or electric) may also be used, not recommended for products thicker than 7/16 in.
 - Better:** Circular saw equipped with a dust collection feature (e.g. Roan® saw) and a HardieBlade saw blade.
 - Good:** Circular saw equipped with a HardieBlade saw blade.

INDOORS

- DO NOT grind or cut with a power saw indoors. Cut using shears (manual, pneumatic or electric) or the score and snap method, not recommended for products thicker than 7/16 in.
- DO NOT dry sweep dust; use wet dust suppression or vacuum to collect dust.
 - For maximum dust reduction, James Hardie recommends using the "Best" cutting practices. Always follow the equipment manufacturer's instructions for proper operation.
 - For best performance when cutting with a circular saw, James Hardie recommends using HardieBlade® saw blades.
 - Go to jameshardiepros.com for additional cutting and dust control recommendations.

IMPORTANT: The Occupational Safety and Health Administration (OSHA) regulates workplace exposure to silica dust. For construction sites, OSHA has deemed that cutting fiber cement with a circular saw having a blade diameter less than 8 inches and connected to a commercially available dust collection system per manufacturer's instructions results in exposures below the OSHA Permissible Exposure Limit (PEL) for respirable crystalline silica, without the need for additional respiratory protection.

If you are unsure about how to comply with OSHA silica dust regulations, consult a qualified industrial hygienist or safety professional, or contact your James Hardie technical sales representative for assistance. James Hardie makes no representation or warranty that adopting a particular cutting practice will assure your compliance with OSHA rules or other applicable laws and safety requirements.

GENERAL REQUIREMENTS:

- These instructions to be used for single family installations only. For Commercial / Multi-Family installation requirements go to www.JamesHardiePros.com
- References to the 2015 National Building Code (NBC) of Canada are made throughout this document. Local building code requirements may supersede the NBC in some locations.
- Where local building code requires a capillary break (Rainscreens, Furring, Etc.), fastener specifications per the CCMC can still be used as long as the required fastener penetration is achieved into an approved nailable substrate.
- HardiePanel® siding can be installed over furring strips (in accordance with local building code requirements). HardiePanel vertical siding can be installed over braced wood or steel studs, 20 gauge (0.836 mm) minimum to 16 gauge (1.367 mm) maximum, spaced a maximum of 610mm (24 in) o.c. Irregularities in framing and sheathing can mirror through the finished application. Refer to the table on page 3 of this document and 'Fastener Requirements' for specific arrangement and type of fasteners for your application.
- Information on installing James Hardie products over non-nailable substrates (ex: gypsum, foam, etc.) can be located in JH Tech Bulletin 19 at www.jameshardie.com
- A water-resistive barrier is required in accordance with Part 9.27.3.2 of the NBC. The water-resistive barrier must be appropriately installed with penetration and junction flashings in accordance with Part 9.27.3 of the NBC. James Hardie will assume no responsibility for water infiltration.
- Adjacent finished grade must slope away from the building in accordance with local building codes.
- Do not install James Hardie products, such that they may remain in contact with standing water.
- HardiePanel vertical siding may be installed on vertical wall applications only.
- DO NOT use HardiePanel vertical siding in Fascia or Trim applications.
- For larger projects, including commercial and multi-family projects, where the span of the wall is significant in length, the designer and/or architect should take into consideration the coefficient of thermal expansion and moisture movement of the product in their design. These values can be found in the Technical Bulletin #8 "Expansion Characteristics" at www.JamesHardie.com.
- James Hardie Building Products may be installed on buildings with a maximum mean roof height of 25.9 m (85 feet). For information on installations above 60 feet, please contact JH technical support.
- Minimum standard panel design size is 12" x 16". Note: Panels may be notched and cut to size to fit between windows, doors, corners, etc.

INSTALLATION:

Fastener

- Position fasteners 9.5mm (3/8 in.) from panel edges and no closer than 50mm (2in.) away from corners. Do not nail into corners.
- HardiePanel vertical siding must be joined on stud.
 - Double stud may be required to maintain minimum edge nailing distances.
 - When screws are used to attach panels to steel studs/furring, the screws shall have wing tips. If screws do not have wing tips, then pre-drilling is required. (Not applicable when using pins) Follow chart below for pre-drilling:

| SCREW | PRE-DRILL | HEAD DIAMETER |
|--------|-----------|---------------|
| No. 8 | 7/32 in | Min 0.323 in |
| No. 10 | 1/4 in | Min 0.323 in |

Joint Treatment

- Vertical Joints - Install panels in moderate contact (fig. 1), alternatively joints may also be covered with battens, PVC or metal jointers or caulked (Not applicable to ColorPlus® Finish) (fig. 2).
- Horizontal Joints - Provide Z-flashing at all horizontal joints (fig. 3).

Figure 3

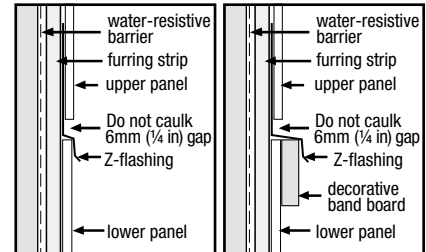

Figure 4

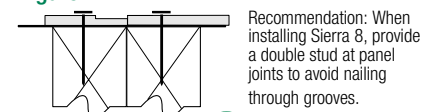

Figure 1

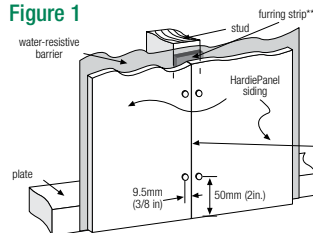
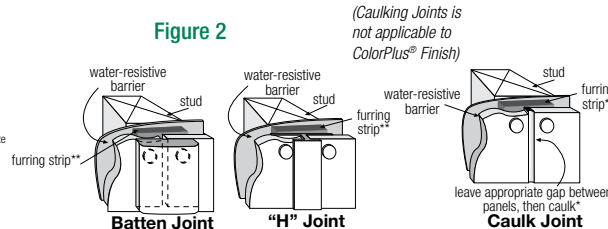

Figure 2



*Apply caulk in accordance with caulk manufacturer's written application instructions.
 **James Hardie recommends installing a rainscreen (an air gap) between the HardiePanel siding and the water-resistive barrier as a best practice.
 James Hardie recommends that you consult your design professional if you have questions regarding the use of rainscreen on your single family project.
 †For additional information on HardieWrap™ Weather Barrier, consult James Hardie at 1-866-4Hardie or www.hardiewrap.com



SMOOTH | CEDARMILL® | STUCCO | SIERRA 8

Visit jameshardiepros.com for the most recent version.



HS1235 P1/4 01/20



CLEARANCE AND FLASHING REQUIREMENTS

Install siding and trim products in compliance of Part 9.27.2.4 of the NBC which requires a minimum 200mm (8 in) for clearance between the bottom edge of the siding and the adjacent finished grade.

Figure 3
Roof to Wall

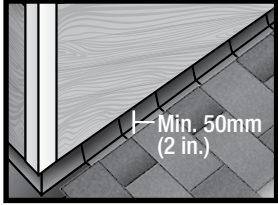

Figure 4
Horizontal Flashing

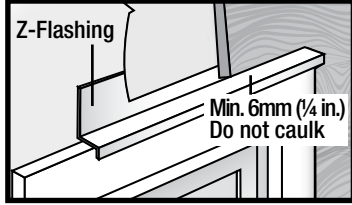

Figure 5
Kickout Flashing

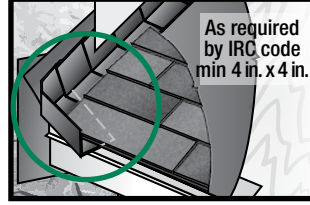
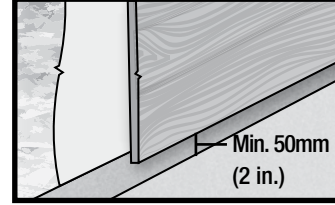

Figure 6
Slabs, Path, Steps to Siding



At the juncture of the roof and vertical surfaces, flashing and counterflashing shall be installed per the roofing manufacturer's instructions. Part 9.27.2.4 requires a minimum 50mm (2 in) clearance between the roofing and the bottom edge of the siding and trim. (fig. 3)

Figure 7
Deck to Wall

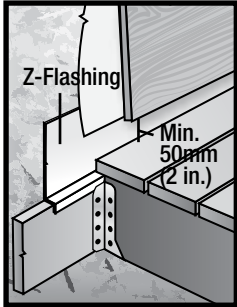

Figure 8
Ground to Siding

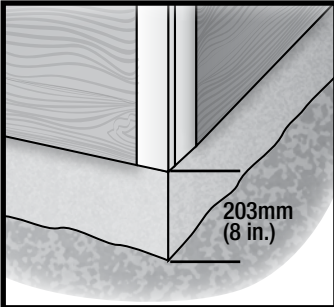

Figure 9
Gutter to Siding

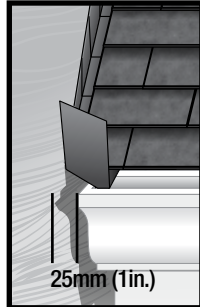

Figure 10
Sheltered Areas

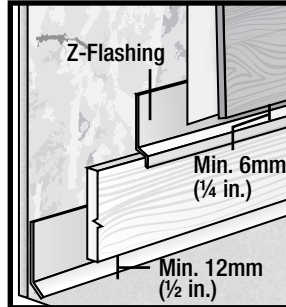

Figure 11
Mortar/Masonry

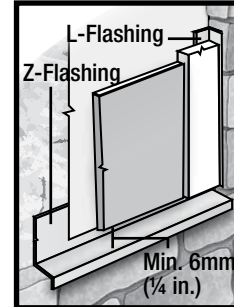

Figure 12
Drip Edge

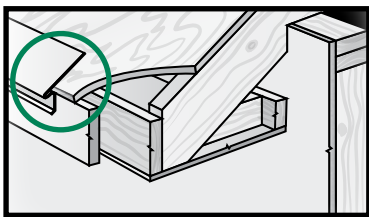

Figure 13
Block Penetration

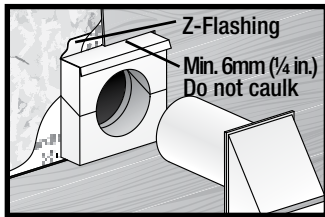
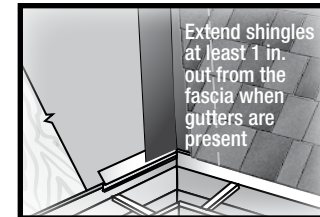
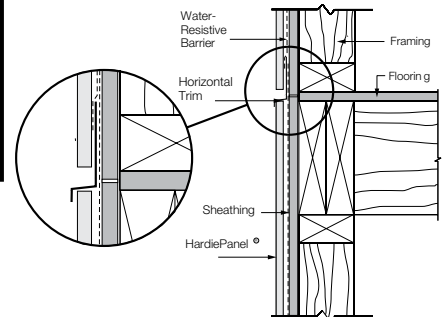

Figure 14
Valley/Shingle Extension



Do not bridge floors with HardiePanel® siding. Horizontal joints should always be created between floors, see below.



GENERAL FASTENING REQUIREMENTS

Fasteners must be corrosion resistant, galvanized, or stainless steel. Electro-galvanized are acceptable but may exhibit premature corrosion. James Hardie recommends the use of quality, hot-dipped galvanized nails. James Hardie is not responsible for the corrosion resistance of fasteners. Stainless steel fasteners are recommended when installing James Hardie® products near the ocean, large bodies of water, or in very humid climates.

Manufacturers of ACQ and CA preservative-treated wood recommend spacer materials or other physical barriers to prevent direct contact of ACQ or CA preservative-treated wood and aluminum products. Fasteners used to attach HardieTrim Tabs to preservative-treated wood shall be of hot dipped zinc-coated galvanized steel or stainless steel and in accordance to 2009 IRC R317.3 or 2009 IBC 2304.9.5

- Consult applicable product evaluation or listing for correct fasteners type and placement to achieve specified design wind loads.
- NOTE: Published wind loads may not be applicable to all areas where Local Building Codes have specific jurisdiction. Consult James Hardie Technical Services if you are unsure of applicable compliance documentation.
- Drive fasteners perpendicular to siding and framing.
- Fastener heads should fit snug against siding (no air space).
- NOTE: Whenever a structural member is present, HardiePanel® should be fastened with even spacing to the structural member. The tables allowing direct to OSB or plywood should only be used when traditional framing is not available.

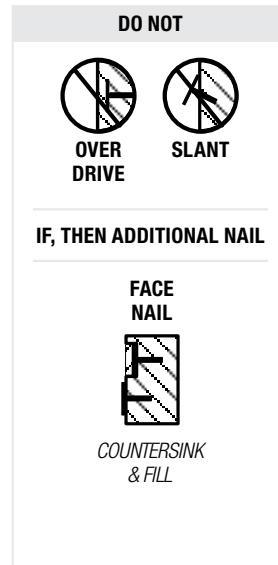
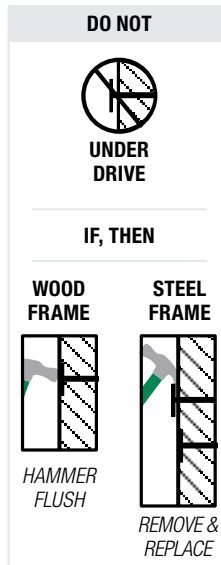
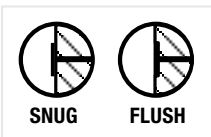



COMPLIANCE:

HardiePanel vertical siding complies with ASTM Specification C1186 (Grade II, Type A) and ISO Standard 8336 (Category A, Class 2, Level I). When tested in accordance with CAN/ULC-S102, the product is recognized to have the following properties: Flame Spread Rating: 0, Smoke Developed Classification: 0. When tested in accordance with CAN/ULC-S114, the product is recognized as noncombustible.

RECOGNITION:

HardiePanel vertical siding is recognized as an exterior wall cladding in CCMC Evaluation Report 12678-R. This document should also be consulted for additional information concerning the suitability of this product for specific applications. For technical assistance, call 1-800-9-HARDIE.

FIRE-RESISTIVE CONSTRUCTION:

HardiePanel vertical siding is recognized as a component in 1-hour & 2-hour fire-related wall construction when tested in accordance with CAN/ULC-S101. Details of the listed assemblies may be found at: <https://bpdirectory.intertek.com>

ALLOWABLE LOADS FOR STRUCTURAL EXTERIOR HARDIEPANEL® VERTICAL SIDING

| FRAME TYPES | STUD SPACING | VERTICAL FASTENER SPACING | FASTENERS | RATING (kPa) | |
|--------------|----------------|---------------------------|---|--|--|
| | | | | Non-Post-Disaster Building (Height < 12 m) | Non-Post-Disaster Building (Height < 20 m) |
| 2x4 SPF wood | 610 mm (24 in) | 305 mm (12 in) | 6d common nail (2.87mm x 6.75 mm x 50.8 mm) | Q50<0.55 | Q50<0.45 |
| 2x4 SPF wood | 610 mm (24 in) | 203 mm (8 in) | 6d siding nail (2.34 mm x 5.64 mm x 50.8 mm) | Q50<0.55 | Q50<0.45 |
| 2x4 SPF wood | 610 mm (24 in) | 152 mm (6 in) | 6d common nail (2.87mm x 6.75 mm x 50.8 mm) | Q50<0.75 | Q50<0.65 |
| 2x4 SPF wood | 610 mm (24 in) | 152 mm (6 in) | 4d ring shank siding nail (2.41 mm x 5.56 mm x 38 mm) | Q50<0.55 | Q50<0.45 |
| 20-ga. steel | 610 mm (24 in) | 305 mm (12 in) | #8 bugle head screw (8.2 mm x 31.8 mm) | Q50<0.45 | N/A |
| 20-ga. steel | 610 mm (24 in) | 203 mm (8 in) | 1.5 in ET&F fastener (2.54 mm x 6.35 mm x 38 mm) | Q50<0.55 | Q50<0.45 |
| 20-ga. steel | 406 mm (16 in) | 152 mm (6 in) | 1.5 in ET&F fastener (2.54 mm x 6.35 mm x 38 mm) | Q50<0.75 | Q50<0.65 |

METRIC TO IMPERIAL CONVERSION TABLE

The following table provides a conversion of the nominal metric measurements presented in these installation instructions to nominal Imperial fraction measurement values

| mm | inches | mm | inches | mm | inches | mm | inches |
|-----|--------|-----|--------|-----|--------|-----|--------|
| 2.3 | 3/32 | 6.7 | 17/64 | 25 | 1 | 150 | 6 |
| 2.5 | 3/32 | 7.5 | 5/16 | 38 | 1-1/2 | 203 | 8 |
| 2.8 | 7/64 | 8.2 | 21/64 | 50 | 2 | 305 | 12 |
| 5.7 | 7/32 | 9 | 23/64 | 92 | 3-5/8 | 406 | 16 |
| 6.2 | 1/4 | 12 | 15/32 | 102 | 4 | 610 | 24 |





CUT EDGE TREATMENT

Caulk, paint or prime all field cut edges. James Hardie touch-up kits are required to touch-up ColorPlus products.

CAULKING

For best results use an Elastomeric Joint Sealant complying with ASTM C920 Grade NS, Class 25 or higher or a Latex Joint Sealant complying with ASTM C834. Caulking/Sealant must be applied in accordance with the caulking/sealant manufacturer's written instructions. **Note: some caulking manufacturers do not allow "tooling".**

PAINTING

DO NOT use stain, oil/alkyd base paint, or powder coating on James Hardie® products. James Hardie products must be painted within 180 days for primed product and 90 days for unprimed. 100% acrylic topcoats are recommended. Do not paint when wet. For application rates refer to paint manufacturers specifications. Back-rolling is recommended if the siding is sprayed.

PAINTING JAMES HARDIE® SIDING AND TRIM PRODUCTS WITH COLORPLUS® TECHNOLOGY

When repainting ColorPlus products, James Hardie recommends the following regarding surface preparation and topcoat application:

- Ensure the surface is clean, dry, and free of any dust, dirt, or mildew
- Repriming is normally not necessary
- 100% acrylic topcoats are recommended
- DO NOT use stain, oil/alkyd base paint, or powder coating on James Hardie® Products.
- Apply finish coat in accordance with paint manufacturers written instructions regarding coverage, application methods, and application temperature
- DO NOT caulk nail heads when using ColorPlus products, refer to the ColorPlus touch-up section

COLORPLUS® TECHNOLOGY CAULKING, TOUCH-UP & LAMINATE

- Care should be taken when handling and cutting James Hardie ColorPlus® products. During installation use a wet soft cloth or soft brush to gently wipe off any residue or construction dust left on the product, then rinse with a garden hose.
- Touch up nicks, scrapes and nail heads using the ColorPlus® Technology touch-up applicator. Touch-up should be used sparingly. If large areas require touch-up, replace the damaged area with a new piece of siding with ColorPlus® Technology.
- Laminate sheet must be removed immediately after installation of each course.
- Terminate non-factory cut edges into trim where possible, and caulk. Color matched caulks are available from your ColorPlus® product dealer.
- Treat all other non-factory cut edges using the ColorPlus Technology edge coat, available from your ColorPlus product dealer.

Note: James Hardie does not warrant the usage of third party touch-up or paints used as touch-up on James Hardie ColorPlus products.

Problems with appearance or performance arising from use of third party touch-up paints or paints used as touch-up that are not James Hardie touch-up will not be covered under the James Hardie ColorPlus Limited Finish Warranty.

SILICA WARNING

DANGER: May cause cancer if dust from product is inhaled. Causes damage to lungs and respiratory system through prolonged or repeated inhalation of dust from product. Refer to the current product Safety Data Sheet before use. The hazard associated with fiber cement arises from crystalline silica present in the dust generated by activities such as cutting, machining, drilling, routing, sawing, crushing, or otherwise abrading fiber cement, and when cleaning up, disposing of or moving the dust. When doing any of these activities in a manner that generates dust you must (1) comply with the OSHA standard for silica dust and/or other applicable law, (2) follow James Hardie cutting instructions to reduce or limit the release of dust; (3) warn others in the area to avoid breathing the dust; (4) when using mechanical saw or high speed cutting tools, work outdoors and use dust collection equipment; and (5) if no other dust controls are available, wear a dust mask or respirator that meets NIOSH requirements (e.g. N-95 dust mask). During clean-up, use a well maintained vacuum and filter appropriate for capturing fine (respirable) dust or use wet clean-up methods - never dry sweep.

WARNING: This product can expose you to chemicals including respirable crystalline silica, which is known to the State of California to cause cancer. For more information go to P65Warnings.ca.gov.

