

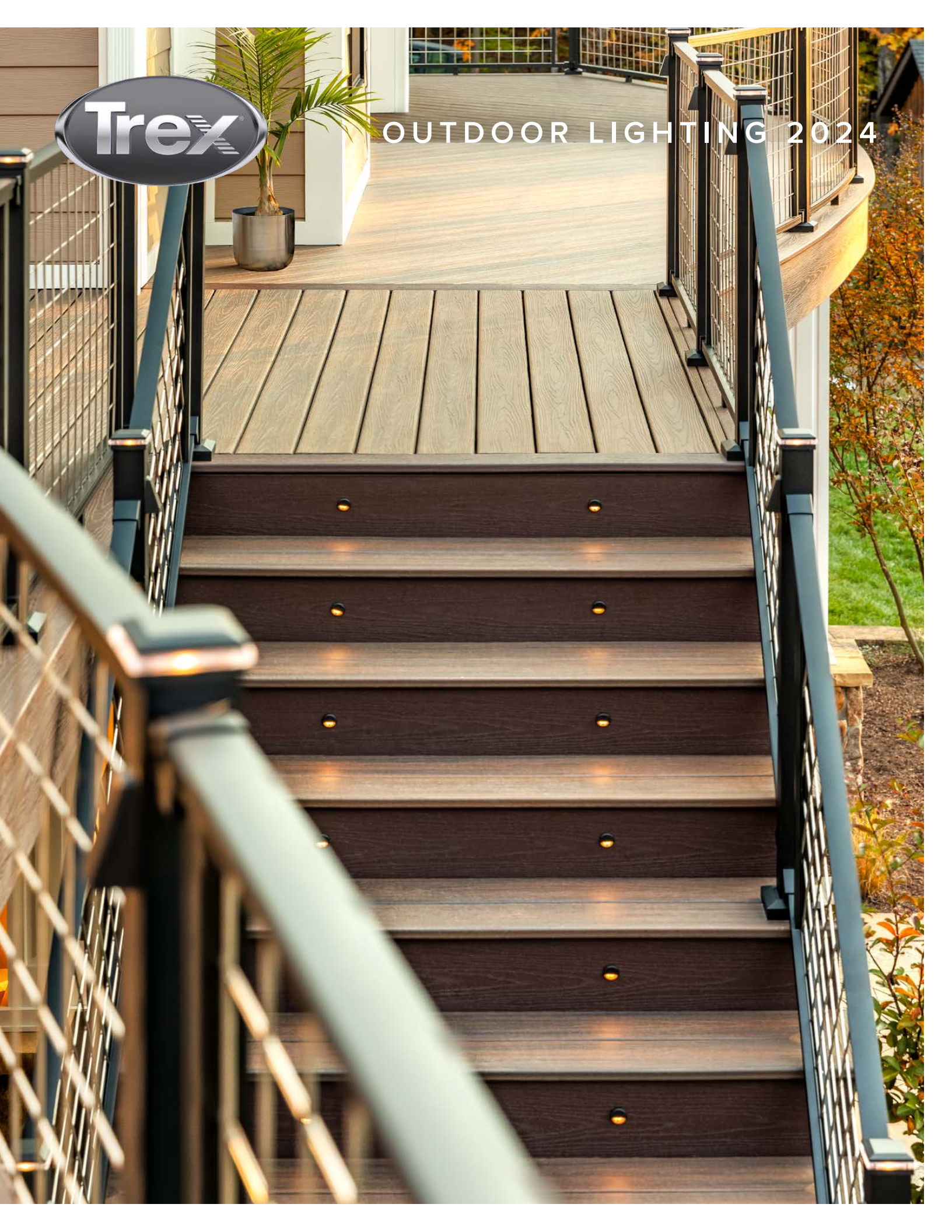

OUTDOOR LIGHTING 2024





Meet the
light of
the party.

Trex® Outdoor Lighting

With the right light, you can take any outdoor space from invisible to inviting. That's why Trex offers a range of lighting options that cast a warm glow on various deck areas—from stairs to railing posts to deck perimeters.

Trex® Outdoor Lighting enhances curb appeal with energy-efficient illumination that makes for safer nighttime strolls and impressive deckside ambiance. Best of all, the lights install in a snap and disappear into their surroundings for a truly sophisticated look.

HIGH PERFORMANCE

- » Energy-efficient CREE® LEDs give off long-lasting illumination*
- » Dimmable glow matches the mood of any outdoor party or dinner
- » Remains weather-proof and salt-air resistant in the toughest climates
- » Offers total lighting control via timer and optional dimmer with remote

PERENNIAL BEAUTY

- » Sophisticated fixtures create custom lighting effects and designs
- » Ambient light improves the safety of surfaces and stairways
- » Out of sight during the day, beautiful light every night
- » Available in a variety of colors to complement any outdoor space

TREX® THROUGH AND THROUGH

- » Part of a complete Trex package
- » Trex LightHub® connection system makes set-up a snap for DIYers
- » Easily builds into new decks or retrofits into existing ones
- » Earth-friendly LEDs are up to 9.1 times more efficient than incandescent lighting
- » Protected under warranty for years of outdoor use**

Set up and control your deck lights with the Trex LightHub connection system. Installation videos are available at [trex.com](https://www.trex.com).

CREE
Trex proudly uses CREE LEDs

ETL US
Intertek
4000334

*CREE® is a registered trademark of Cree, Inc.
**For the terms of warranties on Trex® Outdoor Lighting, see page 18 or visit [trex.com](https://www.trex.com)



TOP TO BOTTOM BRILLIANCE

Lit at every level, courtesy of post cap lights, stair riser lights and under-deck illumination.



STEP BY STEP

Stair riser lights illuminate just where they need to, creating safe, beautiful pathways.



FROM INVISIBLE TO INVITING

Wedge deck rail lights turn a daytime-only deck into a warm, inviting space for entertaining.

DECK LIGHTING PROFILES



SOLAR POST CAP LIGHT

Powered by the sun, the Trex® Solar Post Cap Lights add ambiance to your outdoor space without the electric bill or wires. These caps are compatible with the Trex 4x4 composite post sleeves and are available in our three most popular railing colors.



COMPOSITE POST CAP LIGHT

Tucked discreetly under the cap, post cap lights provide a warm downward glow and easy wayfinding.

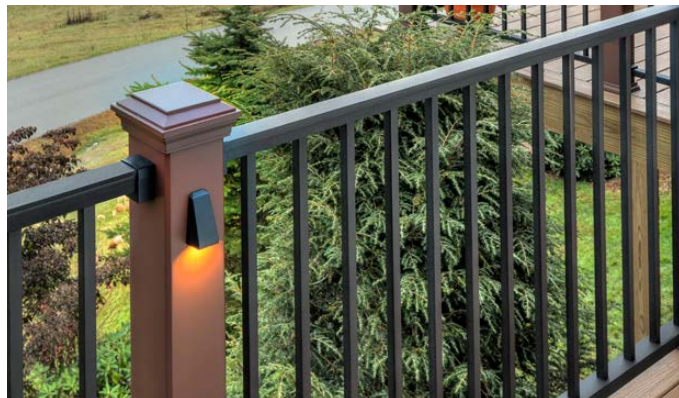

WEDGE DECK RAIL LIGHT

Sleek and understated, this versatile post lamp can be installed on 2.5-inch aluminum posts as well as composite sleeves.



ALUMINUM POST CAP LIGHT

Shining in all directions, aluminum post cap lights work seamlessly with Trex Signature® 2.5-inch aluminum posts.



STAIR RISER LIGHT

Installed into step risers, these lights are durable enough to handle years of passing foot traffic.



DECK RAIL LIGHT

These indirect lights reside directly on the rail post to illuminate the beautiful deck below.



RECESSED DECK LIGHT

These subtle dot lights install flush on the deck boards to efficiently light the way.

TREX® OUTDOOR LIGHTING

| COMPONENT & DESCRIPTION | ITEM # |
|---|--|
| Flat Post Cap Light <ul style="list-style-type: none"> » 4" x 4" LED Post Cap Light [4.55 in x 4.55 in (115 mm x 115 mm) actual internal dimensions] Use with Trex 4 in Composite Railing Posts » 5.5 ft (1.67 m) Male LightHub® Lead |  BKSQLEDCAP4X4C WTSQLEDCAP4X4C VLSQLEDCAP4X4C RSSQLEDCAP4X4C BKSOLAR4X4CAP WTSOLAR4X4CAP VLSOLAR4X4CAP |
| Aluminum Post Cap Light <ul style="list-style-type: none"> » 2.5" x 2.5" LED Aluminum Post Cap Light [2.6 in x 2.6 in (66 mm x 66 mm) actual internal dimensions] Use with Trex 2.5 in Aluminum Railing Posts » 5.5 ft (1.67 m) Male LightHub® Lead |  BKALCAPLED25 BZALCAPLED25 WTALCAPLED25 |
| Aluminum Deck Rail Light <ul style="list-style-type: none"> » LED Deck Rail Light [2.75 in (69 mm) OD] » 5.5 ft (1.67 m) Male LightHub® Lead |  BKLAMPLEDC BZLAMPLEDC WTLAMPLEDC |
| Aluminum Wedge Deck Rail Light <ul style="list-style-type: none"> » LED Wedge Deck Rail Light [1.875 in wide x 3 in high (47 mm x 76 mm) actual dimensions] Compatible with all Trex Railing Posts » 5.5 ft (1.67 m) Male LightHub® Lead |  BKALPOSTLAMPLED BZALPOSTLAMPLED WTALPOSTLAMPLED |
| Aluminum Stair Riser Light <ul style="list-style-type: none"> » 4 LED Riser Lights [1.25 in (31 mm) OD] » 5.5 ft (1.67 m) Male LightHub® Lead |  BKRISERLED4PKC BZRISERLED4PKC WTRISERLED4PKC |
| Recessed Deck Light <ul style="list-style-type: none"> » 4 LED Recessed Lights [1 in (25 mm) OD] » 5.5 ft (1.67 m) Male LightHub® Lead |  RECESSLED4PKC |
| ACCESSORIES | ITEM # |
| Transformer with Timer <ul style="list-style-type: none"> » Output Voltage: 12VDC » Output Power: 100W or 30W » Output Current: 8.3A or 2.5A » Photo-Activated Timer » 20 ft (6.09 m) LightHub® Wire Extension Cable |  8.3A, 100W: DIMMABLE 83DLTRANSFORMERCC 2.5A, 30W: 25DLTRANSFORMER |
| Multi-zone Transformer Adapter |  DL5TFSPLIT1PK |
| Dimmer <ul style="list-style-type: none"> » Single Channel with Remote |  DLDIMMER |
| Wifi Lighting Controller |  DLWIFIC |
| Forstner Bit <ul style="list-style-type: none"> » Pack of 6 » 1 in (25 mm) |  DLBIT6PK |
| LightHub® Accessories <ul style="list-style-type: none"> » 3-Way Splitter » 6-Way Splitter » 5 ft (1.52 m) Wire Extension Cable » 10 ft (3.04 m) Wire Extension Cable » 20 ft (6.09 m) Wire Extension Cable » Female to Female Adapter |  DL3SPLIT6PK DL6SPLIT4PK DL5FTWR4PK DL10FTWR4PK DL20FTWR4PK DLFADAP6PK |

TEXTURED ALUMINUM FINISH FOR: DECK RAIL LIGHTS, STAIR RISER LIGHTS & ALUMINUM POST CAP LIGHTS

Classic White

Bronze

Charcoal Black

SMOOTH COMPOSITE FINISH FOR: POST CAP LIGHTS

Classic White

Charcoal Black

Rope Swing

Vintage Lantern

HOW TO INSTALL TREX® DECKLIGHTING

PARTS

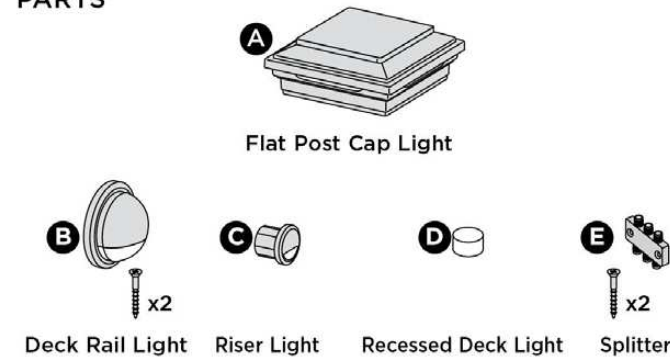

- » 5ft, 10ft and 20ft connection/extension wires sold separately (these are male-to-male connection wires).

Lighting and Wiring Overview

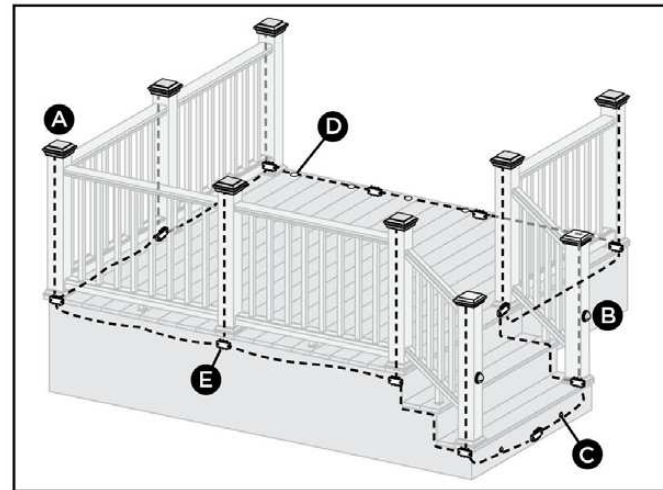

NOTE: All wiring and splitters are mounted to the inside of framing. Picture above is a general representation of where to place them.

TOOLS NEEDED

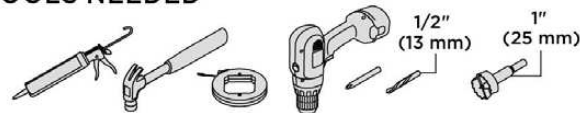

WARNING:

- » **DO NOT INSTALL DECKLIGHTING IN CLOSE PROXIMITY TO POOLS OR HOT TUBS AS CHEMICALS FROM THE WATER CAN DAMAGE LIGHTING FIXTURES.**
- » **DO NOT INSTALL WIRING UNDER HEAVY WEIGHT OR LOAD AS THIS CAN DAMAGE WIRING.**

NOTE: Avoid railing brackets and locations for deck rail lights when running wires up posts.

NOTE: It is recommended to install wiring and splitters before decking and railing have been installed. **DO NOT** run wires between joists and deck boards.

HELPFUL TIPS

- » Please note that Trex lighting operates on DC power. **NEVER** mix AC and DC fixtures on the same circuit. Doing so will result in extremely premature fixture failure and is not covered by the Trex limited warranty. **You must use a Trex transformer on all Trex lighting installations.**
- » **Never fully drive staples when securing wire. Wire should move under staple.**
- » **ALWAYS** protect any wire that is close to the ground with conduit or wire loom to prevent rodent damage.
- » Cap all unused female connections with caps provided or weather-resistant silicone to prevent water damage or corrosion.
- » Each dimmer operates on a separate remote.
- » It is recommended to have power source installed and turned on when installing lights to ensure all components work.
- » When installing wiring, avoid extreme angles, pressure, or tension on the wiring, as this can cause pinching of the wiring and create a lighting failure.

HOW TO INSTALL TREX® DECKLIGHTING/CONTINUED

General Information

- » Refer to www.trex.com for instructional videos on how to install Trex DeckLighting.
- » **USE TREX TRANSFORMER ONLY.** Use of any other transformer voids warranty.

Transformer Capacity by Type

| Type of Light | 8.3A Transformer (83 DL TRANSFORMER) | 2.5A Transformer (2.5 DL TRANSFORMER) |
|---------------|--------------------------------------|---------------------------------------|
| Riser | 79 | 27 |
| Recessed | 79 | 27 |
| Post Cap | 79 | 27 |
| Deck Rail | 79 | 27 |

Above listing is for maximum number of each individual light fixture type. For mixing and matching requirements, visit Trex.com and use the interactive Lighting Transformer Calculator (located on the Trex® Decklighting™ product page).

Planning

NOTE: When designing your deck, plan locations of lights, power supply, timer, and dimmer. These should be accessible for service. Installing a GFCI outlet is **REQUIRED** to help prevent damage to lighting from electrical surges.

1. The dimmer remote will work in a 30' (9 m) radius of the unit.
2. Dimmer should be installed in a dry location.
3. Timer must be installed vertically with receptacle facing downwards. Timer must be at least 1' (.305 m) from ground level when installed as per federal safety code height regulations. Timer must be in view of the sun to use the dusk/dawn feature.

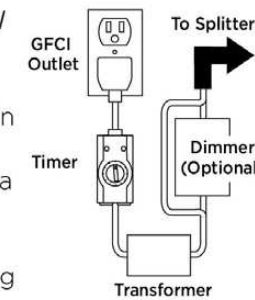

Installing Wiring

NOTES:

- » It is recommended to install wiring and splitters before decking and railing have been installed.
- » Use male-to-male connection wire (lengths vary) that will connect to each required splitter.

1. Wiring must be run under decking structure and behind stringers. **DO NOT** run wires between deck boards and joists. Staple to frame with cable staples at least 1/4" (6 mm) wide. **DO NOT** crush wire insulation with staples.

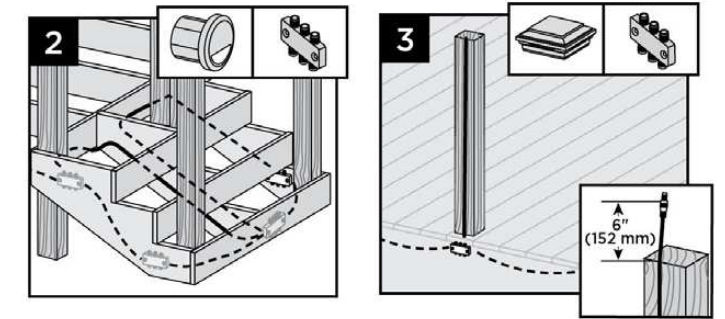
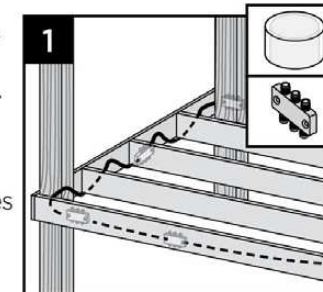

2. Wiring can be run under deck and behind risers. Staple to frame with cable staples at least 1/4" (6 mm) wide. **DO NOT** crush wire insulation with staples.
3. Remove 5' (1.52 m) lead wire that is connected to post cap and attach wire to post with male connection at top of post (female connection would be at bottom of post and connect into splitter). Avoid running wire on side of post where railing brackets or deck rail lights will be installed. Leave approximately 6" (152 mm) of lead at top to make connections. Staple to frame and posts with cable staples at least 1/4" (6 mm) wide. **DO NOT** crush wire insulation with staples.

Making Connections

1. Install splitters to inside of framing using hardware provided. Install at every post base where lighting is present and depending on spacing in between each riser and recessed light.

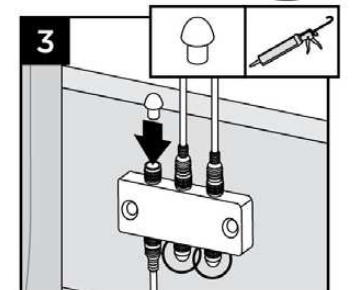
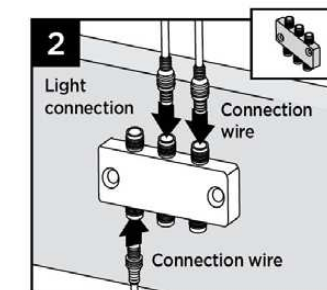
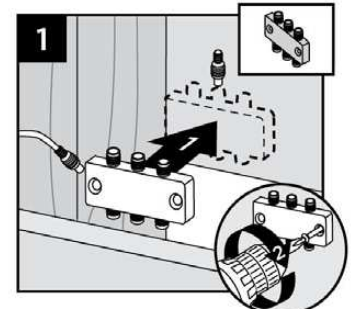

2. Attach male lead from lights to female connections on splitter. Also attach male-to-male connection wires in between each splitter. Continue until all wiring from lights are attached to splitters and connector wires are attached in between splitters.
3. Cap off all unused female connections on splitters using caps provided or weather-resistant silicone.

HOW TO INSTALL TREX® DECKLIGHTING/CONTINUED

Timer Operation Instructions

- Select the mode of operation:
 - » Dusk to Dawn
 - » 2-8 hours
 - » Always "ON"
 - » "OFF"

Program repeats daily. When power is flowing to lights, green light above POWER is on.

Installing Post Cap Lights

NOTE: Install post cap lights after the railing system, post sleeve skirt, and post sleeve have been installed.

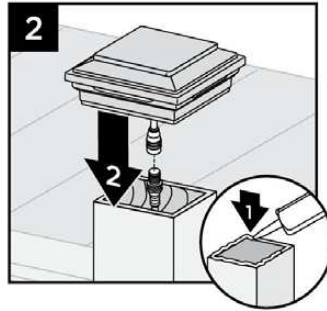
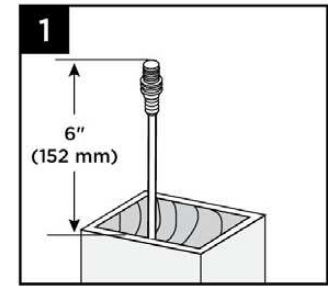

- Connect male lead from wiring to female connector from cap. Also attach male-to-male connection wires in between each splitter. Continue until all wiring from lights is attached to splitters and connector wires are attached in between splitters. (See Making Connections section for details.)
- After verifying wiring is correct by turning lights on, attach cap to top of post with silicone caulk.

Installing Deck Rail Lights

NOTE: Instructions shown below are for new deck installation and are shown BEFORE railing system has been installed.

- Place post sleeve over pressure-treated post and mark desired height, centered on post sleeve for deck rail light location.

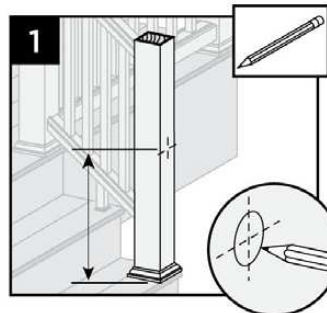

NOTE: If deck boards are not installed yet, place a deck board on framing to ensure post sleeve is at correct height.

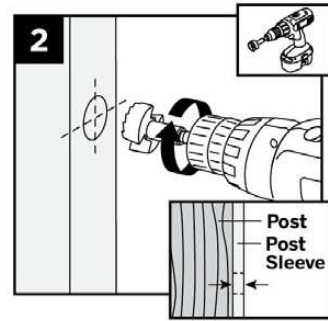

- Drill a 1" (25 mm) hole through post sleeve. Drill deep enough to mark location on pressure-treated post.

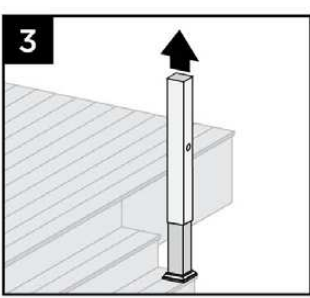

- Remove the post sleeve from the post.

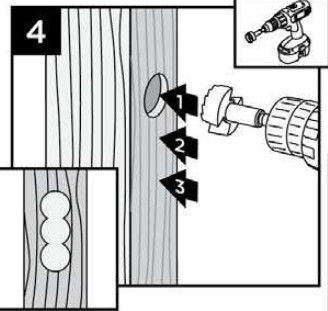

- Drill out existing hole on pressure-treated post 3/4" (19 mm) deep. Drill two additional holes vertically below main hole—this will allow space for wiring after post sleeve is attached.
- Leave enough slack at top of lead wire and attach lead wire to post using heavy duty tape. Attach lead wire to splitter under decking.

TIP: To hold lead wire in place at drilled-out location, use painters tape.

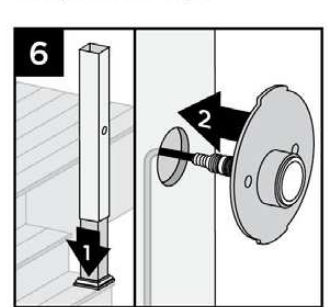

- Slide post sleeve back over post. If using a post sleeve skirt, make sure to install the skirt first. Connect plug on deck rail light to lead wire and tuck wiring into previously drilled-out pockets on post.
- Align holes for screws horizontally and attach fixture base to post with provided screws.

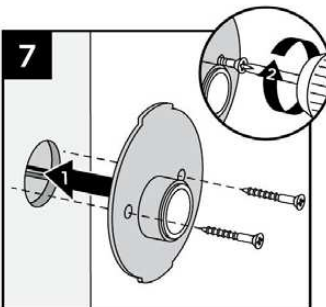

HOW TO INSTALL TREX® DECKLIGHTING/CONTINUED

- Line up polycarbonate lens with fixture housing. Twist onto fixture base. Continue until all wiring from lights is attached to splitters and connector wires are attached in between splitters. (See Making Connections section for details.)

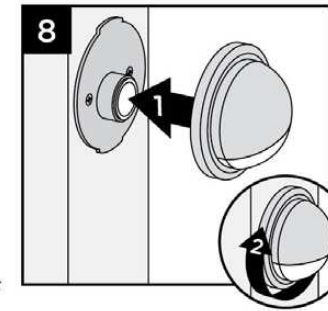

NOTE: If railing has already been installed, lead wires will need to be fished through the post sleeve to reach the desired location for the deck rail light. In some cases, if the provided lead wire does not fit (due to connector size), the wire connectors can be cut off and wire nuts can be used. Test lights with the power on. If lights that are wired with this method do not function, then switch the connector wires.

Installing Riser Lights

NOTE: Install riser lights after stairs and risers have been installed.

- Mark locations for each light, generally 4" (102 mm) above tread. Consult local codes for lighting requirements.

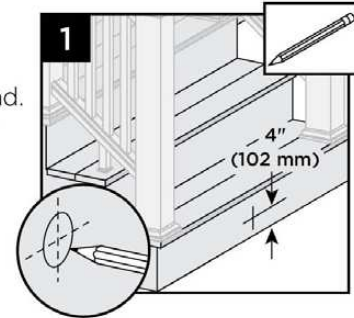

NOTE: If possible, avoid locations over stringers as holes will be more difficult to create.

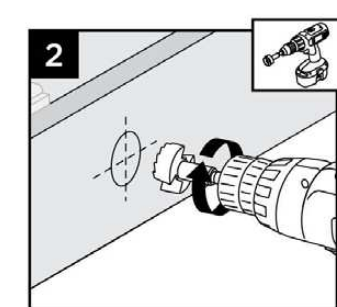

- Drill a 1" (25 mm) diameter hole at least 1" (25 mm) deep into riser. If riser material is thicker than 1" (25 mm), use a 1/2" (13 mm) drill bit to create a passage for wires.
- Thread wires through hole. Press light into hole, ensuring lens is horizontal. Make connections behind stairs from male lead wire from recessed light into female connection on splitter. Also attach male-to-male connection wires in between each splitter.

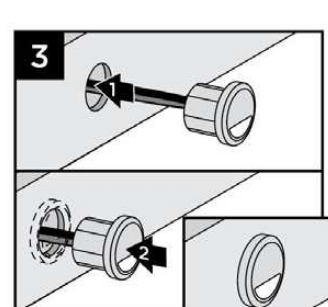

Continue until all wiring from lights is attached to splitters and connector wires are attached in between splitters. (See Making Connections section for details.)

NOTE: DO NOT install riser light or deck rail light into top or bottom rails or balusters.

Installing Recessed Deck Lights

NOTE: Install recessed deck lights after installing decking.

- Mark locations for lights in deck boards.

NOTE: If possible, avoid locations over joists as holes will be more difficult to create.

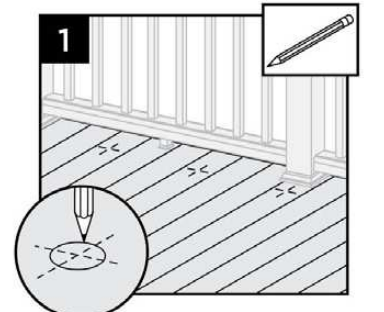

- Drill a 1" (25 mm) diameter hole 3/4" (19 mm) deep into deck board. Hole cannot go all the way through deck board or light will fall through. Make sure drill bit is perpendicular to board. Drill a 1/2" (13 mm) diameter hole in base of the first hole through deck board.

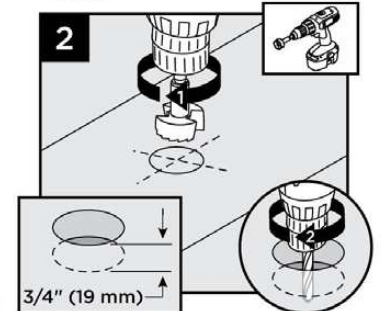

- Thread wires through hole. **DO NOT pull LED into hole by pulling on wires. This may damage wires or LED.** Press light into hole until flush with surface. Make connections under deck from male lead wire from riser light into female connection on splitter. Also attach male-to-male connection wires in between each splitter. Continue until all wiring from lights is attached to splitters and connector wires are attached in between splitters. (See Making Connections section for details.)

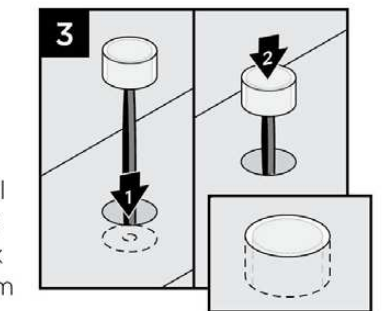

HOW TO INSTALL TREX SIGNATURE® CAP LIGHT (can only be used on Trex Signature® posts)

PARTS



- » 5ft, 10ft and 20ft connection/extension wires sold separately (these are male-to-male connection wires).

TOOLS NEEDED

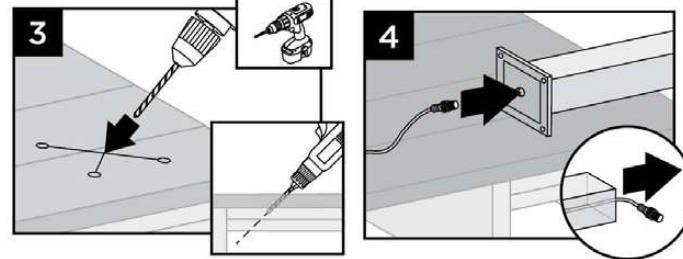

- Using a 9/16" (14 mm) x 6" (152 mm [or longer]) drill bit, drill a diagonal hole through the decking and blocking. Ensure that the angle will allow wire to not be pinched by support plate under blocking (if using Trex ALPOSTHWDECK mounting kit). (See Making Connections section for details.)
- Turn post upside down and fish 5' male-to-male wire (provided) through hole in baseplate.

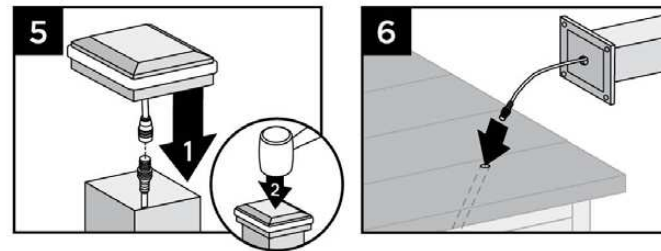

- Connect the female connector on the post cap light to this wire and, using a rubber mallet, gently tap the cap onto top of post until it is secure.
- Turn post over and carefully fish wire through hole created in Step 3 to underside of the deck. Ensure exit point of wire under blocking will not be pinched by ALPOSTHWDECK plate.
- Mount post per instructions.

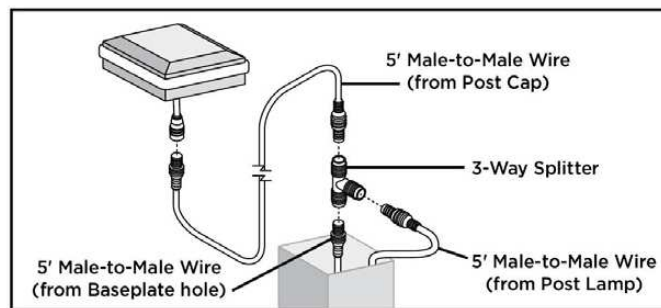

NOTE: If connecting a Trex Wedge Deck Rail Light as well, a 3-way adapter and extra 5' male-to-male wire (not provided) can be used inside the post so that only one wire must be run through the hole in the base of the post (and post blocking). This is optional.

Helpful Tips

- » Leave slack in wire to make fixture terminations.
- » Post lamps work well at changes in levels of a deck—at the top or the bottom of the stairs, or in conjunction with post cap lights.
- » Splitters should be used at each post that has lights and depending on spacing in between each riser and recessed light.
- » Cap all unused female connections with caps provided or weather-resistant silicone to prevent water damage or corrosion.
- » The splitter is cross-linked so there is no specified plug for lights versus lead wires.
- » Leads attached to each light are approx. 5.5' (1.67 m) in length and have male terminals to plug into splitter.
- » Use a separate dimmer control for each light type for maximum control.
- » It is recommended to have power source on when installing lights to ensure all components work.

Transformer Capacity by Type

| Type of Light | 8.3A Transformer (83 DL TRANSFORMER) | 2.5A Transformer (2.5 DL TRANSFORMER) |
|--------------------|--------------------------------------|---------------------------------------|
| Signature Post Cap | 59 | 29 |

Above listing is for maximum number of each individual light fixture type. For mixing and matching requirements, visit Trex.com and use the interactive Lighting Transformer Calculator (located on the Trex® Decklighting product page).

Installing Post Cap Lights

NOTE: Instructions shown below are for new deck installation and are shown **BEFORE** railing system has been installed.

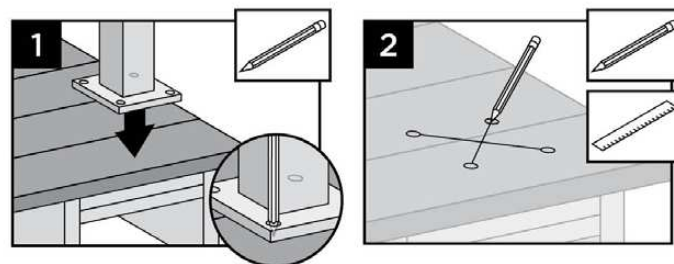

- Before attaching post to deck, locate placement of post and mark desired bolt locations.
- Using a straight edge, mark an "X" between the four bolt locations.

HOW TO INSTALL TREX® WEDGE DECK RAIL LIGHT

PARTS

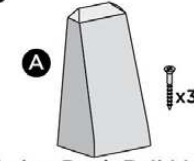

Wedge Deck Rail Light (includes 5ft male-to-male wire)

- » 5ft, 10ft and 20ft connection/extension wires sold separately (these are male-to-male connection wires).

TOOLS NEEDED

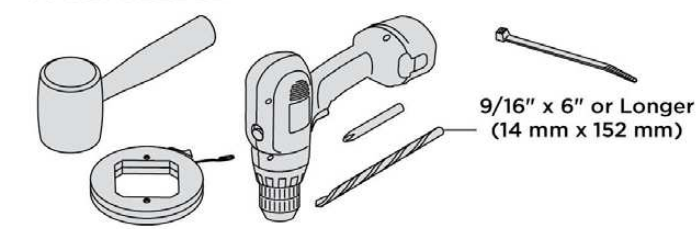

Helpful Tips

- » Leave slack in wire to make fixture terminations.
- » Deck rail lights work well at changes in levels of a deck—at the top or the bottom of the stairs, or in conjunction with post cap lights.
- » Splitters should be used at each post that has lights and depending on spacing in between each riser and recessed light.
- » Cap all unused female connections with caps provided or weather-resistant silicone to prevent water damage or corrosion.
- » The splitter is cross-linked so there is no specified plug for lights versus lead wires.
- » Leads attached to each light are approx. 5.5' (1.67 m) in length and have male terminals to plug into splitter.
- » Use a separate dimmer control for each light type for maximum control.
- » It is recommended to have power source on when installing lights to ensure all components work.

Transformer Capacity by Type

| Type of Light | 8.3A Transformer (83 DL TRANSFORMER) | 2.5A Transformer (2.5 DL TRANSFORMER) |
|---------------------------------|--------------------------------------|---------------------------------------|
| Signature Wedge Deck Rail Light | 79 | 27 |

Above listing is for maximum number of each individual light fixture type. For mixing and matching requirements, visit Trex.com and use the interactive Lighting Transformer Calculator (located on the Trex® Decklighting product page).

Installing Post Lamps

NOTE: Instructions shown below are for new deck installation and are shown **BEFORE** railing system has been installed.

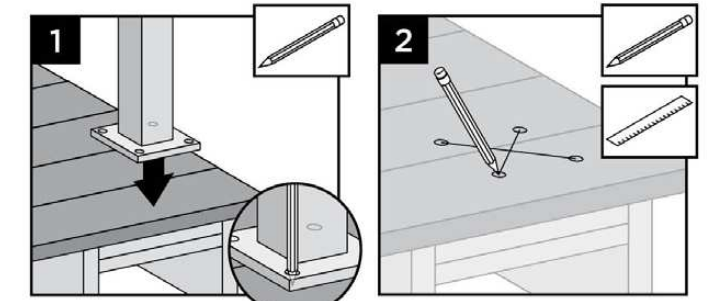

- Before attaching post to deck, locate placement of post and mark desired bolt locations.
- Using a straight edge, mark an "X" between the four bolt locations.

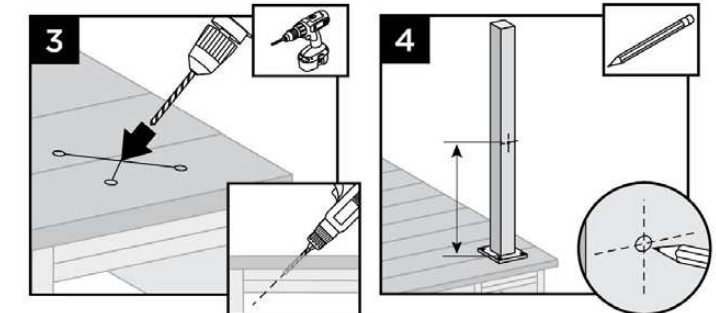

- Using a 9/16" (14 mm) x 6" (152 mm [or longer]) drill bit, drill a diagonal hole through the decking and blocking. Ensure that the angle will allow wire to not be pinched by support plate under blocking (if using Trex ALPOSTHWDECK mounting kit).
- Locate placement of post lamp. Mark entry point of the wire.
- Drill 9/16" (14 mm) hole where wire will enter post.

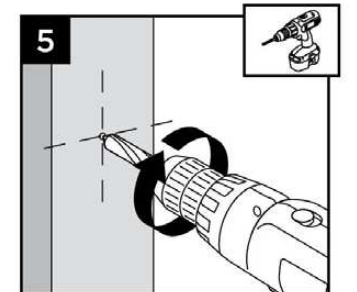

HOW TO INSTALL TREX® WEDGE DECK RAIL LIGHT/CONTINUED

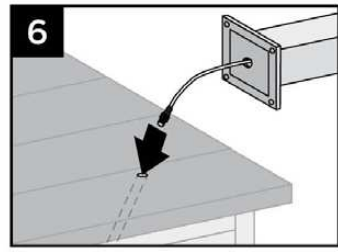

6. Turn post upside down and fish 5' male-to-male wire (*provided*) through hole in baseplate.

7a. If connecting a Wedge Deck Rail Light only, pull wire through hole.

TIP: Insert a zip-tie loop (or small grabber tool) through 9/16" (14 mm) hole. Fish wire through loop in zip-tie. Pull wire through hole with zip-tie.

7b. If connecting a Trex Signature post cap light as well, and using the 3-way splitter (*see note after Step 12*), simply run one wire through the hole created in Step 5 to the top of the post.

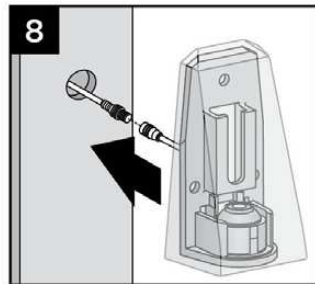
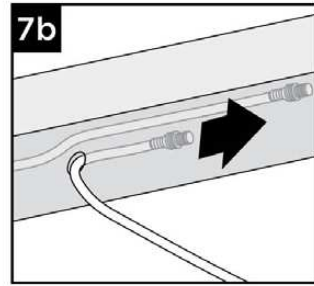

8. Connect male connector to female connector on light housing.

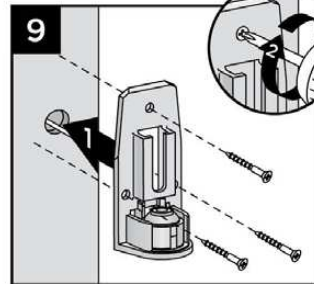

9. Place light and attach backing plate to post with three screws (*provided*).

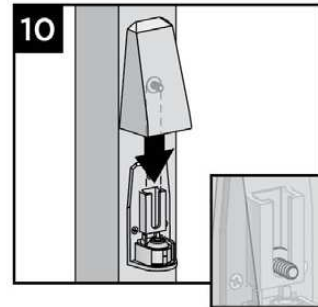
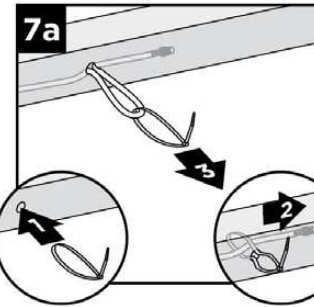

10. Slide light cover down over backing plate, adjusting mounting screws as necessary to achieve a tight fit.

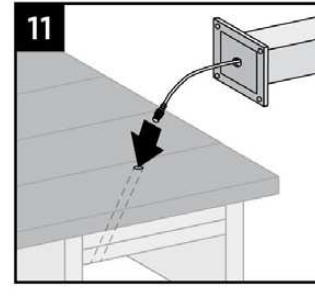

11. Turn post over and carefully fish wire through hole created in Step 3 to underside of the deck. Ensure exit point of wire under blocking will not be pinched by ALPOSTHWDECK plate.

12. Mount post per instructions.

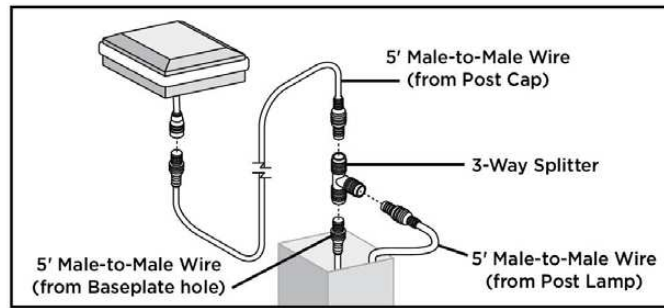

NOTE: If connecting a Trex Signature post cap light as well, a 3-way adapter and extra 5' male-to-male wire (*not provided*) can be used inside the post so that only one wire must be run through the hole in the base of the post (*and post blocking*). This is optional.

HOW TO PROGRAM DIMMER REMOTE

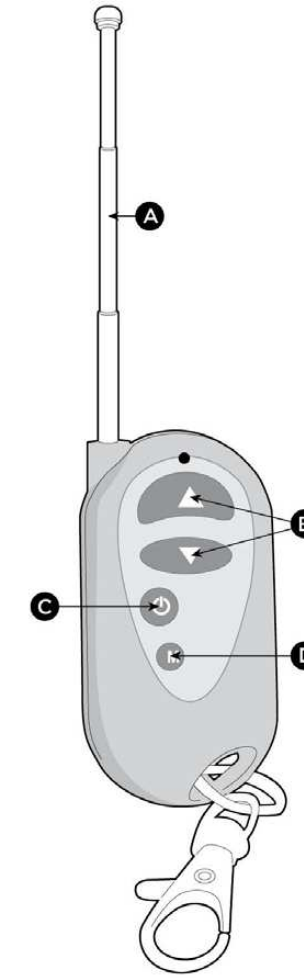

- A. **ALWAYS** keep antenna fully extended for maximum range.
- B. Up/Down arrows gradually dim or brighten lighting.
- C. On/Off button cycles lights ON/OFF.
- D. Mode button cycles through 3 preset dimming levels: High, Medium, Low, and Off.

NOTE: First, make sure the red light is illuminated on the remote. If there is no red light and the product is new, contact 1-800 BUY-TREX for a replacement. If the product is not new, the A27 battery is replaceable.

1. Install dimmer per instructions and make sure lights are ON and working properly.
2. Unplug the transformer to turn lights OFF.

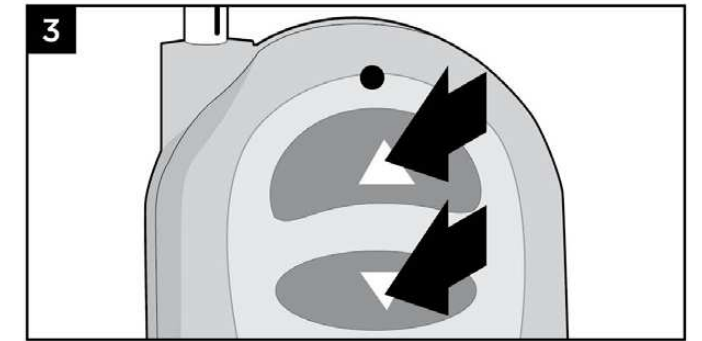
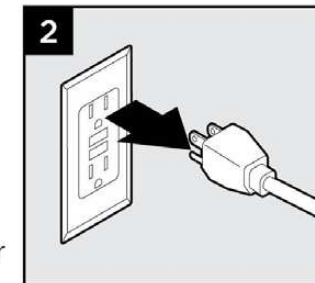

3. Press and hold both the up and down arrow on the dimmer remote simultaneously.

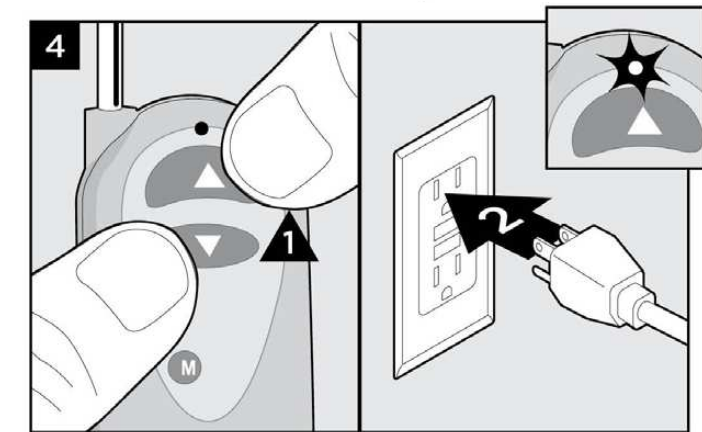

4. With the dimmer arrow buttons held down, plug the transformer back in. The lights should blink once to confirm programming.

5. Release the up and down arrows on the remote and test remote to confirm proper operation.

TREX® WIFI CONTROLLER SETUP INSTALLATION INSTRUCTIONS

The Trex® WiFi Controller allows you to control your Trex® Decklighting from anywhere. With the easy-to-use Bond Home app, you can monitor status, set schedules and fine-tune the brightness of your installations. The controller is compatible with the Trex® Light Hub system and can be used to control up to 60W of LED lights.

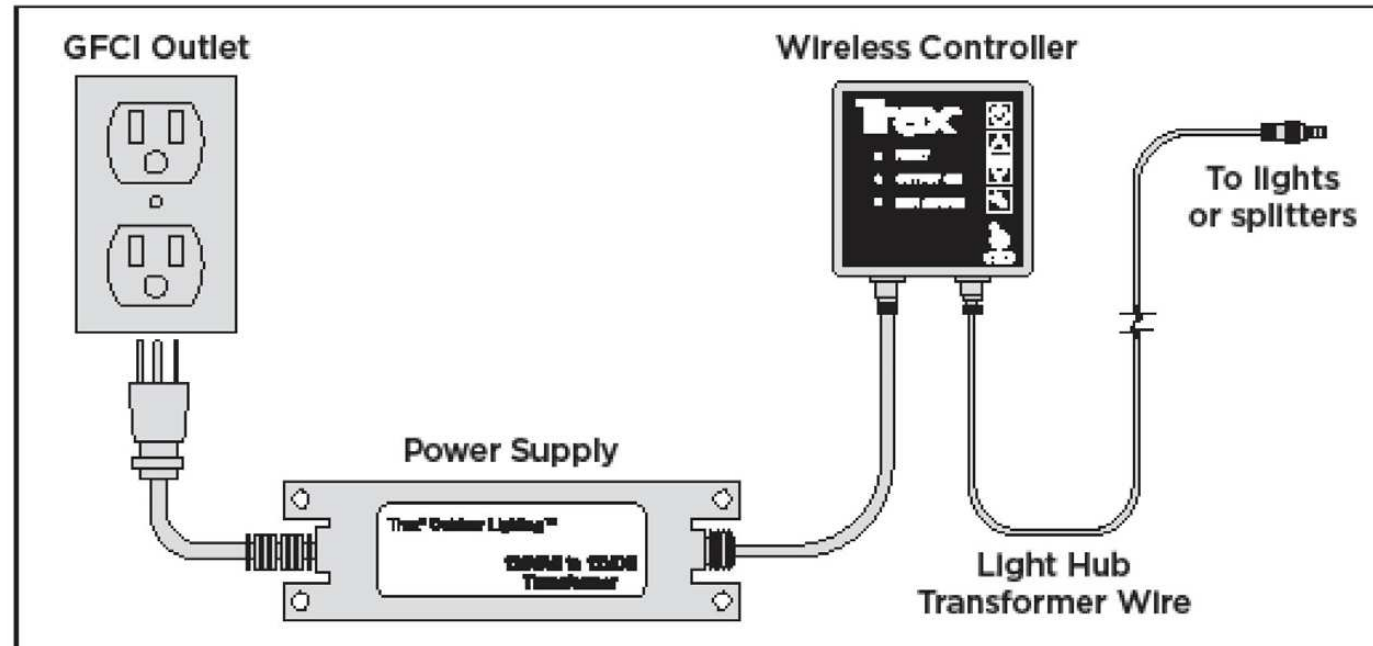

Controller Installation

1. With the power supply unplugged, connect the input lead of the Trex WiFi Controller to the Trex Transformer.
2. Connect the Light Hub Transformer Wire to the output terminal of the Trex WiFi controller then to the first light installation.

CAUTION:

When making connection between a Light Hub connector or splitter, observe the polarity key to make a proper connection.

The male and female connectors have a flat side that **MUST MATCH UP**. Do not force the connections together.

Light Hub connectors are waterproof, but for increased protection the dielectric grease should be added prior to connection.



3. Plug the power supply into a GFCI-protected wall socket. If you see the red "FAULT" light, your system has reversed polarity. Check the polarity key on your input cable and correct any problems before proceeding.
Note: WiFi controller has built-in overload protection. System will fault when used to control more than 60W of LED lights. To reset: **unplug** transformer from the power source, decrease control to 60W of LED lights or less, then plug back into power source.
4. Mount the WiFi controller in place with the included pressure sensitive adhesive strips and/or by replacing the installed black screws with the included 1.5" black wood screws.

For wireless connection support, visit the help center in the app.

TREX® WIFI CONTROLLER SETUP INSTALLATION INSTRUCTIONS

Controller Setup

1. On an Android or iOS device, download the Bond Home App.
2. Create an account and sign in to the app.
3. Trex WiFi Controller is a "Smart by Bond" device. Follow the in-app prompts to add the controller to your account and connect it to your home WiFi network.



Smart by
bond

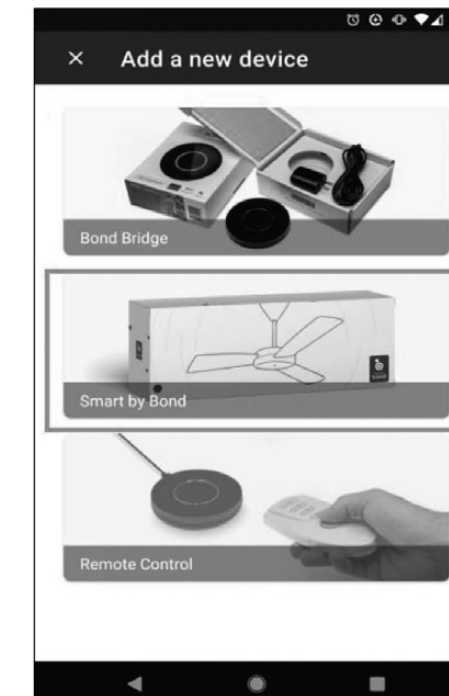
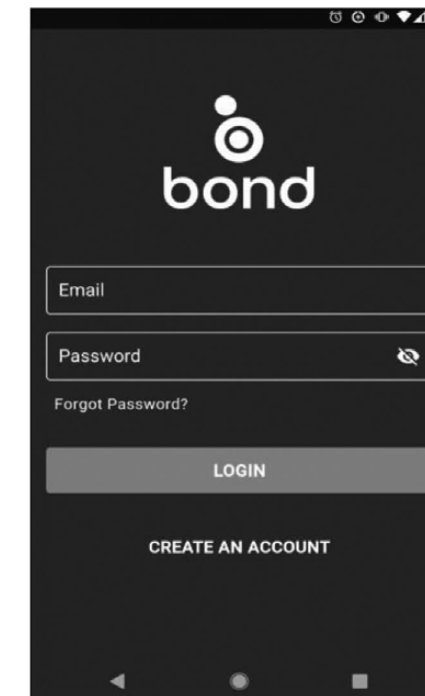

TREX® SOLAR POST CAP DECKLIGHTING INSTALLATION INSTRUCTIONS

HOW TO INSTALL TREX® SOLAR POST CAP LIGHT

PARTS

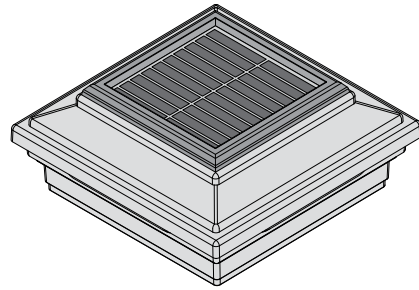

HELPFUL TIPS

- » Install the solar post cap in locations that receive the most amount of sunlight.
- » If the installation location experiences long periods of temperatures below 32°F (0°C) it is recommended to shut the post cap off to prolong the battery life.
- » Maintenance - Periodically clean the glass solar panel to be free of dust and debris for optimum charging performance using a water dampened cloth.

TOOLS NEEDED

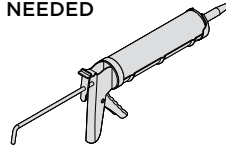

CAUTION:

Do not short the pins of the battery connector. Doing so will damage the battery and may cause it to overheat and burst. When installing a replacement battery the male and female connectors have a flat side that **MUST MATCH UP** for polarity. Do not force the connections together. Failure to match polarity **will** damage the controller board.

Do not puncture or allow sharp objects to come into contact with the battery.

Do not attempt removal of battery jacket.

Do not dispose of battery in a fire.

Do not attempt to alter or modify the battery from its original manufacture design.

The battery is intended for use in the TREX Solar Post Cap any other use is prohibited and will void the warranty.

Check local regulations for proper battery disposal.

Keep out of reach of children.

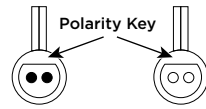

1. Turn the post cap upside down.

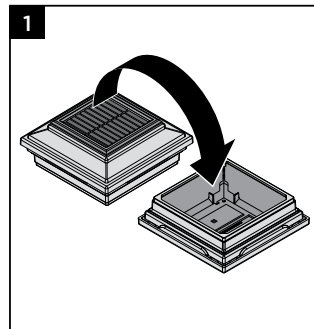

2. Press the switch to turn the post cap on.

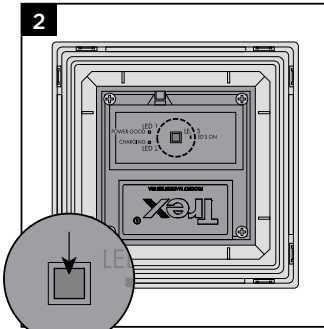

3. Cover the solar panel and the LED 3 (LED's On) will turn on as well as the post cap LEDs.

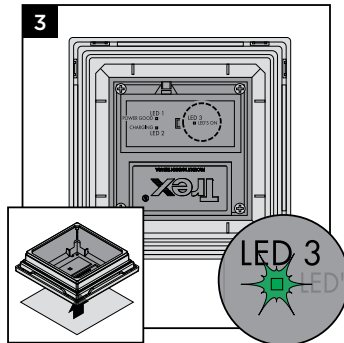

4. Turn the post cap over so the solar panel is facing direct sunlight.

LED 1 (Power good) and LED 2 (Charging) will turn on. LED 3 (LED's On) and the post cap LEDs will turn off.

Note if there is not enough sunlight then LED 2 (Charging) may not turn on.

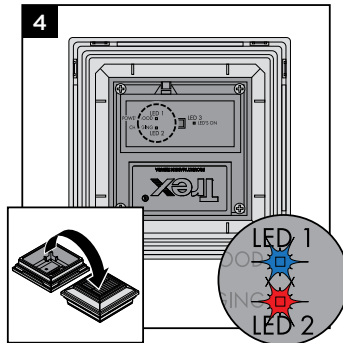

TREX® SOLAR POST CAP DECKLIGHTING INSTALLATION INSTRUCTIONS

HOW TO INSTALL TREX® SOLAR POST CAP LIGHT/CONTINUED

5. Add a small button of silicone to the tabs on the bottom of the post cap.

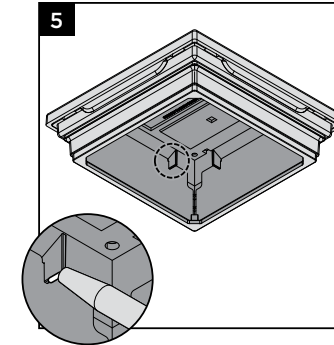

6. Seat the post cap on top of the post sleeve.

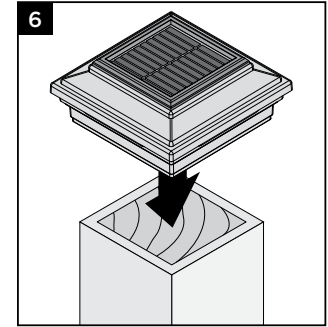

7. The post cap is ready for use.

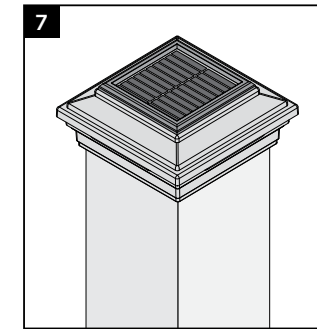

1. Trex solar post cap lights should be installed in a location with as much direct sunlight as possible for best performance.
2. Shading can **reduce** the charging performance by as much as 50-80%.
3. Solar light run time is based on:
 - Angle of sunlight for recharging
 - Sun/Cloud conditions for recharging
 - Duration of sunlight for recharging
 - Seasonal conditions for recharging
 - How clean the solar panel is for charging

Angle of the Sun in Different Seasons

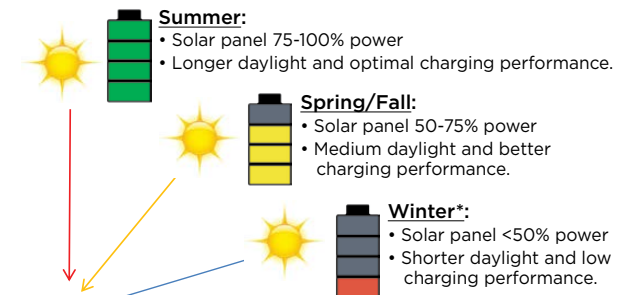

*It is not recommended to charge or operate the Trex solar post cap in temperatures below 32°F (0°C).

Effective Charge in Sunlight VS Cloud Coverage

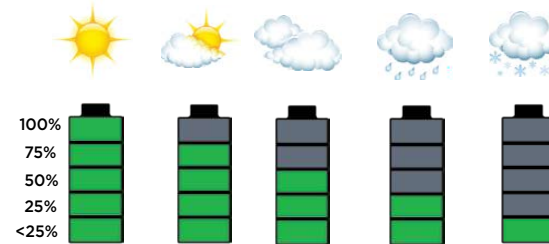

Run times vary significantly with actual daily weather conditions, post cap installation location, battery condition and numerous other factors.

If the installation location experiences long periods of temperatures below 32°F (0°C) it is recommended to shut the post cap off to prolong the battery life.

kWh High to Low Map

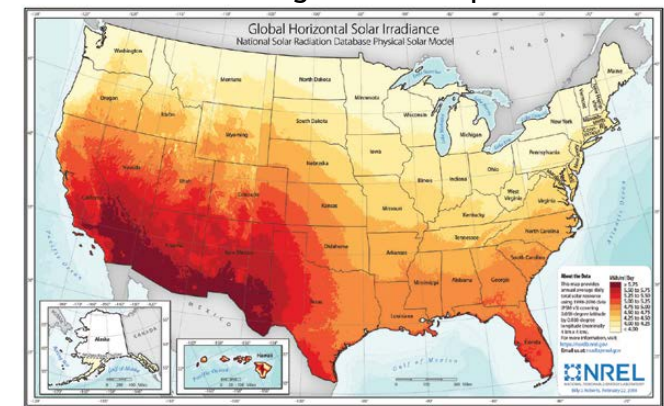

Note this map provides annual average daily total solar resource. The darker color regions have a higher charge efficiency potential while lighter shaded regions have lower efficiency potential. This map does not account for daily adverse weather conditions that may occur such as rain, overcast and snow fall.



TREX RAILING AND ANCILLARY PRODUCTS LIMITED WARRANTY

Trex Company, Inc. (hereinafter "Trex") warrants to the original end-use purchaser ("Purchaser") that, for the applicable Warranty Period set forth in Table I below, when properly installed, used and maintained under normal use and service conditions, and in accordance with Trex's written instructions, Trex® product set forth in Table I below (the "Product") shall be free from material defects in workmanship and materials, and shall not split, splinter, rot or suffer structural damage from termites or fungal decay.

Residential/Commercial Application: For purposes of this warranty, a "residential application" shall refer to an installation of the Product on an individual residence, and a "commercial application" shall refer to any installation of the Product other than on an individual residence.

Term of Limited Warranty: The term of this Limited Warranty for a Product (the "Warranty Period") begins on the date of original purchase and shall be equal to the number of years set forth next to such Product in Table I below.

TABLE I

| Product | Residential Warranty Period | Commercial Warranty Period |
|--|-----------------------------|----------------------------|
| Trex Signature® Railing | 25 Years | 25 Years |
| Trex Transcend® Railing, Trex Select® Railing, Trex Enhance® Railing, Trex® Fencing, and TrexTrim™ | 25 Years | 10 Years |
| Trex® DeckLighting (LEDs and Housings) | 7 Years | 7 Years |
| Trex® DeckLighting (Transformer, Timer, Dimmer, WiFi Controller, Solar Components) | 3 Years | 3 Years |
| Trex® DeckLighting (Solar Battery) | 1 Year | 1 Year |

Transferability: With respect to a residential application, this warranty may be transferred one (1) time, within the five- (5) year period beginning from the date of original purchase by the Purchaser, to a subsequent buyer of the property upon which the Product was originally installed. With respect to a commercial application, this warranty is freely transferable to subsequent buyers of the property upon which the Product was originally installed.

EXCLUSIONS FROM WARRANTY COVERAGE

Products (excluding Trex® Solar Post Cap Lights) is valid only in each case provided that a Trex transformer is used (with no warranty on any components if a Trex transformer is not used), and any other Trex® DeckLighting parts or accessories not listed in Table I above shall not be warranted; (b) this warranty shall not apply to any Trex products not listed in Table I, including, but not limited to Trex decking products, Trex® Cladding products, Trex® Fascia products and Trex® Fasteners (which each have separate warranties), and (c) with respect to installations where the atmosphere is influenced by a body of salt water (or other contaminant conditions), failure to adhere to the cleaning guidelines available at www.trex.com will void this warranty with respect to any condition resulting from such failure.

The Products must be stored, handled, installed, used and maintained in accordance with instructions provided by Trex, and this Limited Warranty is conditioned upon compliance with all such instructions. Copies of Trex's Installation Guides, Technical Information and Care and Cleaning Guides are available from Trex at the address listed below. The materials may also be obtained on Trex's website at trex.com.

Any information or suggestion by Trex with respect to the Products concerning applications, specifications or compliance with codes and standards, including building or safety codes, is provided solely for Purchaser's convenient reference and is made without any representation as to accuracy or suitability. Purchaser must verify and test the suitability of any information with respect to the Products for Purchaser's specific application.

Trex does not warrant against and is not responsible for any condition attributable to: (1) improper installation of Product and/or failure to abide by Trex's installation guidelines, including but not limited to improper gapping; (2) use of Product beyond normal use and service conditions, or in an application not recommended by Trex's guidelines and local building codes; (3) movement, distortion, collapse or settling of the ground or the supporting structure on which Product is installed; (4) any act of God (such as flooding, hurricane, earthquake, lightning, etc.), environmental condition (such as air pollution, mold, mildew, etc.), staining from foreign substances (such as dirt, grease, oil, etc.), or normal weathering (defined as exposure to sunlight, weather and atmosphere which will cause any colored surface to gradually fade, chalk, or accumulate dirt or stains); (5) variations or changes in color of Product; (6) improper handling, storage, abuse or neglect of Product by Purchaser, the transferee or third parties; or (7) ordinary wear and tear.

PROCEDURE FOR MAKING A CLAIM UNDER THIS LIMITED WARRANTY

To make a claim under this Limited Warranty, Purchaser, or the transferee, shall send to Trex, within the Warranty Period referred to above, a written description and photographs of the claimed defect and proof of purchase, to the following address:

Trex Company, Inc.
Customer Relations
2500 Trex Way
Winchester, VA 22601

Upon confirmation by an authorized Trex representative of a valid claim hereunder, Trex's sole responsibility shall be, at its option, to either: (a) replace the affected Product with new Product in an amount equal to the amount of defective material; or (b) refund the portion of the purchase price paid by Purchaser for such affected Product (not including the cost of its initial installation). Replacement Products will be as close in color, design and quality to the original Products as reasonably possible, in Trex's discretion and determination, but Trex does not guarantee an exact match as colors and designs may change and Trex's obligation as to replacement shall further be limited to replacement with the styles and colors of the Product that are available at the time of the replacement.

THE REMEDIES STATED IN THIS PARAGRAPH ARE PURCHASER'S SOLE AND EXCLUSIVE REMEDIES FOR ANY PRODUCT THAT FAILS TO CONFORM TO THIS LIMITED WARRANTY.

If a valid warranty claim hereunder is made during year eleven (11) or any year thereafter through the expiration of the applicable Warranty Period after the original purchase, recovery will be prorated in accordance with Table II, below. If Trex is providing replacement materials, it may elect to replace the percentage listed in Table II, below, of Product otherwise meeting the requirements for a claim, or if it is refunding the purchase price, it may elect to refund the percentage listed below in Table II of the purchase price of Product otherwise meeting the requirements for a claim.

TABLE II

| Year of Claim | Recovery |
|---------------|----------|
| 11 | 80% |
| 12 | 80% |
| 13 | 80% |
| 14 | 60% |
| 15 | 60% |
| 16 | 60% |
| 17 | 40% |
| 18 | 40% |
| 19 | 40% |
| 20 | 20% |
| 21 | 20% |
| 22 | 20% |
| 23 | 10% |
| 24 | 10% |
| 25 | 10% |



TREX RAILING AND ANCILLARY PRODUCTS LIMITED WARRANTY (CONTINUED)

THE LIMITED WARRANTIES SET FORTH HEREIN ARE THE ONLY WARRANTIES MADE BY TREX IN CONNECTION WITH THESE PRODUCTS. TREX DOES NOT MAKE ANY OTHER WARRANTIES, IMPLIED OR EXPRESS, AND DISCLAIMS ALL OTHER WARRANTIES, INCLUDING, BUT NOT LIMITED TO, ANY IMPLIED WARRANTY OF MERCHANTABILITY OR FITNESS FOR A PARTICULAR PURPOSE. TREX'S SOLE OBLIGATION UNDER THIS LIMITED WARRANTY SHALL BE, AT ITS OPTION, REPLACEMENT OF NON-CONFORMING PRODUCTS OR A REFUND OF THE PURCHASE PRICE, AS DESCRIBED ABOVE. PURCHASER ASSUMES ALL RISK WHATSOEVER AS TO THE RESULT OF THE USE OF THE PRODUCTS PURCHASED, WHETHER USED SINGULARLY OR IN COMBINATION WITH ANY OTHER PRODUCTS OR SUBSTANCES.

THIS LIMITED WARRANTY SHALL NOT COVER AND TREX SHALL NOT BE RESPONSIBLE FOR COSTS AND EXPENSES INCURRED WITH RESPECT TO THE REMOVAL OF DEFECTIVE PRODUCT OR THE INSTALLATION OF REPLACEMENT MATERIALS, INCLUDING BUT NOT LIMITED TO LABOR AND FREIGHT.

No person or entity is authorized by Trex to make and Trex shall not be bound by any statement or representation as to the quality or performance of Product other than as contained in this Limited Warranty. This Limited Warranty may not be altered or amended except in a written instrument signed by Trex and Purchaser.

TO THE FULLEST EXTENT PERMITTED UNDER THE LAW, UNDER NO CIRCUMSTANCES WILL TREX BE LIABLE FOR ANY SPECIAL, INDIRECT, INCIDENTAL, CONSEQUENTIAL, RELIANCE, STATUTORY, SPECIAL, PUNITIVE OR EXEMPLARY DAMAGES, INCLUDING, BUT NOT LIMITED TO, LOST PROFITS, LOSS OF USE, LOSS OF TIME, LOSS OF REVENUES, INCONVENIENCE, LOSS OF BUSINESS OPPORTUNITIES OR DAMAGE TO GOOD WILL OR REPUTATION DAMAGES, WHETHER SUCH DAMAGES ARE SOUGHT IN CONTRACT, IN TORT (INCLUDING BUT NOT LIMITED TO NEGLIGENCE AND STRICT LIABILITY) OR OTHERWISE, EVEN IF ADVISED OF THE POSSIBILITY OF SUCH DAMAGES OR SUCH DAMAGES COULD HAVE BEEN REASONABLY FORESEEN, IN CONNECTION WITH, ARISING OUT OF, OR AS A RESULT OF, THE SALE, DELIVERY, INSTALLATION, USE OR LOSS OF USE OF THE PRODUCTS SOLD

HEREUNDER, OR FOR ANY LIABILITY OF PURCHASER TO ANY THIRD PARTY WITH RESPECT THERETO AND TREX'S LIABILITY FOR NON-PERSONAL INJURY CLAIMS WITH RESPECT TO DEFECTIVE PRODUCT SHALL IN NO EVENT EXCEED THE REPLACEMENT OF SUCH PRODUCT OR REFUND OF THE PURCHASE PRICE, AS DESCRIBED ABOVE.

Some States or Provinces do not allow the exclusion or limitation of incidental or consequential damages, so the above limitation or exclusion may not apply to you. This Limited Warranty gives you specific legal rights, and you may also have other rights that vary from State to State or Province to Province.

Copyright © 2024 Trex Company, Inc.



front: DECKING:
Trex Transcend®
in Spiced Rum (SR)

RAILING:
Trex Signature® Mesh in
Charcoal Black (BK)

back: DECKING:
Trex Enhance® in Saddle (SD)

RAILING: Trex Select®
Classic in Classic White



Engineering What's Next
in Outdoor Living®

DECKING | RAILING | LIGHTING | FASCIA | KITCHENS | FURNITURE | PERGOLA | DRAINAGE
SPIRAL STAIRS | CORNHOLE | LATTICE | CLADDING | HIDDEN FASTENERS | FENCING

Visit [trex.com](https://www.trex.com) or call 1-800-BUY-TREX

FIND US ON



© 2024 Trex Company, Inc. All rights reserved. Trex®, the Trex logo, Trex® Transcend, Trex Signature®, Trex® OutdoorLighting, Trex® DeckLighting and LightHub® are either federally registered trademarks, trademarks or trade dress of Trex Company, Inc., Winchester, Virginia or its licensees.